

# **Car Wash Investment Information**





The following information is made available to help you with investment decisions as they relate to the Car Wash Industry.

Much of the information enclosed was obtained from various periodicals and customer surveys pertaining specifically to this market.

Dultmeier Sales cannot be held accountable for revenue or cost data that does not meet with or match these studies.

**No Guarantee of income, expenses or profits is made or implied by Dultmeier Sales.**

Population, location, building layout, management strategies, climate & competition can all have a great impact with regards to this information and how it affects your business.

For the sake of this information, we will assume all cost and income data is for typical Self-Serve Car Washes.

***Please Let Us Know if You Would Like a Formal Equipment Quote.  
Thank You and Good Washing!***

# Self-Serve Site Analysis

We have put together some basic considerations helpful in selecting your site. Although these items are important, they are no guarantee to success. Good management, proper use of heat and chemicals, the proper equipment to do a consistently good job, preventative maintenance and above all - good housekeeping of location and appearance, are instrumental in arriving at a profitable level of car washing.

## # 1

### Amount of Traffic for Proposed Bays:

1,000 Cars in 24 Hours / Bay .....	+ 10
1,500 Cars in 24 Hours / Bay .....	+ 15
2,000 Cars in 24 Hours / Bay .....	+ 20
2,500 Cars in 24 Hours / Bay .....	+ 30
Tourist, Vacationers .....	+ 20
Local Neighborhood Traffic.....	+ 10

### Traffic Flow in Front of Site:

Evening going-home side of street.....	+ 3
Evening going-home not on side of street.....	- 3

### Speed Limits in Front of Site:

Under 35 MPH.....	+ 5
45 MPH .....	- 3
50 MPH .....	- 5

### Traffic Signals:

If location is within one block of traffic light or stop sign .....	+ 3
If traffic light or stop sign is more than one block from location .....	- 3

### Customer Access:

If location is on frontage road off expressway ....	- 5
If property is on corner .....	+ 3
If property has one curbside to be used for both entrance & exit .....	- 3
If property has one entrance and one exit .....	+ 3
If property has two entrances & two exits .....	+ 5
If property has minimum two-car stack-up room.	+ 5

### Management:

If owner operated .....	+ 5
If owner visits location less than once per week..	- 5
If owner visits location every other day .....	- 3
Full-time attendant proposed .....	+ 5

### Community Car Wash Climate:

In Northeastern U.S.A. ....	+ 10
In Midwestern U.S.A. ....	+ 10
In Southeastern U.S.A. ....	- 10
In Western U.S.A.....	+ 5
In Southwestern U.S.A.....	+ 1
Heavy Seasonal Rainfalls.....	- 5
Frequent snows & thaws .....	+ 10
Factory fallout or other pollution .....	+ 5

### Local Street Conditions:

Dirt roads in area.....	+ 2
-------------------------	-----

Potholes & broken pavement.....	+ 2
Good roads .....	- 2
Winter salts on streets.....	+ 5
No curbs & gutters .....	+ 2

### Nearby Businesses:

Neighborhood shopping center nearby .....	+ 5
For each franchise store nearby add.....	+ 2
If on large shopping mall location.....	- 5

### Visibility:

No sign on street.....	- 15
Sign at street visible at 500 feet.....	+ 10
Sign at street visible at 300 feet.....	+ 5
Bays facing street entrance.....	+ 10
If located on a hill .....	- 2
Drive-in & back-out bays.....	- 15
Lot uphill or downhill from street .....	- 5

### Community Population:

Community under 15,000 people.....	+ 15
If population within 3-mile radius	
1,000 people per bay self-serve.....	+ 5
If population within 3-mile radius	
1,500 people per bay self-serve.....	+ 10
If population within 3-mile radius	
2,000 people per bay self-serve.....	+ 15
If population within 3-mile radius	
2,500 people per bay self-serve.....	+ 20

### Community Growth:

Growing community .....	+ 5
Stable community.....	+ 3
Declining community .....	- 5

### Economic Conditions:

If trading area expensive.....	- 10
If trading area medium (K-Mart).....	+ 5
If trading area poor .....	+ 5
If trading area hard-core (bars/store fronts) .....	- 15

### Self-Serve Competition:

If none within 2-mile radius.....	+ 10
Within 2-mile radius:	
Deduct one point per bay of self-serve competition.	
Within 1-mile radius:	
Deduct two points per bay of self-serve competition.	

### Neighborhood:

Apartments nearby.....	+ 3
Close housing, small or mobile homes.....	+ 3
Homes with no garages.....	+ 2

## # 2

Street parking .....	+ 2
Pick-ups, sports cars, jeeps, boats, vans, small cars .....	+ 5
Executive cars, station wagons prevalent .....	- 5
24-hour shift work in nearby .....	+ 3
Large, expensive homes with large yards nearby .....	- 5
Area divided by river, highway, etc., to isolate from competition .....	+ 3
24-hour business nearby .....	+ 3

### SCORING:

OUTSTANDING .....	Over 100 Points
EXCELLENT .....	90-100 Points
GOOD .....	80-90 Points
FAIR .....	70-80 Points
FIND ANOTHER LOCATION .....	Under 70 Points

Add up all applicable item points total:  
Example: **Overall Points = 100**

Multiply **Overall Points Total** by **10.5** to arrive at **Estimated Average Wash Cycles Per Bay Per Month**  
Example:  $100 \times 10.5 = 1,050$  Estimated Average Wash Cycles Per Bay Per Month.

Multiply **Estimated Average Wash Cycles Per Bay Per Month** by the **Number of Bays** to arrive at **Total Wash Cycles Per Month** count.  
Example:  $1,050 \times 6$  (bays) = 6,300 Total Wash Cycles Per Month

Multiply **Total Wash Cycles Per Month** by your **Price Per Cycle** to arrive at **Estimated Total Wash Income Per Month**.  
Example:  $6,300 \times \$1.50 = \$9,450.00$  Estimated Total Wash Income Per Month

Multiply **Estimated Total Wash Income Per Month** by **.25** to arrive at an **Estimated Total Vending Income Per Month** (Vacuums, towels, etc.).  
Example:  $\$9,450.00 \times .25 = \$2,362.50$  Total Vending Income Per Month

Add **Total Wash Income Per Month** to **Total Vending Income Per Month** to arrive at an overall **Estimated Monthly Gross Income**.  
Example:  $\$9,450.00 + \$2,362.50 = \$11,812.50$  Estimated Monthly Gross Income

**NOTE:** Since number of bays plays an important part in site success, number of bays may be increased or decreased to move location on scoring scale.

This analysis is merely intended as a guide in site selection. Other unknown variables may strongly influence the performance of a specific location. Perform a thorough investigation of the factors involved before you purchase the property. Dultmeier Sales cannot guarantee the success of any car wash location.

### Traffic Count:

1000 Cars per 24 Hours / Bay .....	+ 0
1500 Cars per 24 Hours / Bay .....	+ 5
2000 Cars per 24 Hours / Bay .....	+ 10
2500 Cars per 24 Hours / Bay .....	+ 15
Tourist, vacationers .....	- 2

### Average Speed of Traffic:

Less than 35 MPH .....	+ 5
Less than 45 MPH .....	+ 0
More than 50 MPH .....	- 10

### Access to Lot:

Stoplight / sign within one block .....	+ 5
Divided street .....	- 5
Complicated entrance / exit .....	- 3
Corner lot .....	+ 10
More than one entrance / exit .....	+ 10

### Visibility of Site:

Sign visible both directions 400' .....	+ 10
Sign visible both directions 250' .....	+ 5
Sign visible less than 100' .....	+ 0
Bays perpendicular to street .....	+ 15
Bays parallel to street .....	+ 0
Drive in / back out bays .....	- 15

### Population:

1000 per bay 3 mile radius .....	+ 0
1500 per bay 3 mile radius .....	+ 5
2000 per bay 3 mile radius .....	+ 10
2500 per bay 3 mile radius .....	+ 15

### Population Trends:

Growth area .....	+ 5
Stable area .....	+ 0
Declining area .....	- 20

### Socio-Economic Trends:

Apartments in area .....	+ 3
Small single family housing .....	+ 3
Large % of 4WD, trucks, vans .....	+ 3
Other self-serve stores in area .....	+ 5
Middle to lower income area .....	+ 5
Upper income area .....	- 10

### General Business Factors:

Operating 24 hours .....	+ 10
Operating 12-24 hours .....	+ 5
Operating less than 12 hours .....	- 10
Other self-serve in 3 mile radius .....	- 10
Shopping area nearby .....	+ 10
Located near schools, colleges .....	+ 5

**INSTRUCTIONS:** Add up all applicable items point total. Multiply by 15 to arrive at estimated average monthly cycle count per bay. Multiply this by your price per cycle to arrive at estimated monthly income per bay, multiply this by 1.33 for estimated total including all vending. **Please note:** this is only an exercise to help planning, and in no way is a guarantee of actual performance. (Several answers per category are possible).

Overall total: \_\_\_\_\_ x 15 = Estimated Average Monthly Cycles Per Bay x \_\_\_\_\_ Price x 1.33 = Estimated Monthly Per Bay.

## **Lot Selection**

- A good rule of thumb to follow concerning lot sizing is 100'-120' deep x a minimum of 75' wide depending on the number of bays. (Typical 4 bay self-serve wash would need a lot 100'-120' deep x 100' wide minimum).
- Good access from both directions of traffic flow is also very important.
- Ideal traffic speed should be under 40 mph.
- Lot size and shape will determine if you design a "Drive-in-back-out" or "Drive-through" building. (Income streams tend to favor the "drive-through" design).
- Ideal locations are near residential areas, apartment complexes or busy traffic flow routes.
- A good rule to follow regarding the cost of property is that the monthly lease payment should not exceed 15% of the gross monthly income of the wash.

## **Bay & Building Sizing**

- Ideal bay size is 16' wide x 28' long (inside measurements). Truck bays should be 17-18' wide and 28' long. (Smaller bays will work but are not recommended.)
- Typical pump room is 10'-15' wide x 28' length.
- Typical bay height is 10' for car bays and 12'-14' for truck bays.

## **Building Placement**

- Depending on specific codes your building should be placed on the lot to allow for 1-2 cars minimum to be "stacked" behind each bay waiting to wash. Vacuums can be placed in this area but should not impede the normal flow into the bays.
- Make sure there are adequate drying and vacuuming areas that are out of the main traffic flow.
- Ideally your bays should have a southern exposure to help reduce ice build-up in cold weather conditions.
- Local codes will also have "set-back" requirements on building placement.

## **Inside Vs. Outside Bays**

- In many rural locations washes can be built with an open outside bay for trucks, trailers, tractors, etc.
- However, as a rule an outside bay will bring in only about 40-50% of the revenue of an inside bay.
- It is always better from a revenue standpoint to enclose all bays and build one larger if you feel you will have adequate truck traffic. This bay then can also be used for cars if other bays are busy.

### **Revenue Projections-Bays**

- Studies find that it takes a population base of 1000-1500 people to support 1 self-serve bay. ( A town of 5000 people could theoretically support a total of 5 self-serve bays between all competitors.)
- At this population level the National Average is approximately \* \$1350 per bay, per month of gross income for one self-serve bay. (This is an estimate average only, incomes can and do vary.)

### **Revenue Projections-Vacuums**

- The ideal number of vacuums to have is 1-1/2 vacuums per 1 bay of self-serve. (I.E. a 3- bay wash should have 4-5 vacuums placed somewhere on the lot).
- National average of revenue per vacuum is approximately \* \$222 per vacuum per month in gross revenue. (Incomes can and will vary.)

### **Revenue Projections-Vending**

- National average of vending revenue is approximately \* \$347 per month gross revenue based on offering at least 4 different vending products.

### **Operating Cost Projections**

- Average operating costs (Based on 2006 information) is approximately \*52% of gross income which includes \*9.3% for attendant labor which you may or may not need. \*(Lease payments, income tax, debt reduction or depreciation are not included). These figures can and do vary by region.

### **Options & Features**

- Typical self-serve washes will offer hot wash, hot rinse-winter & cold rinse-summer, hot or cold wax, foamy brush and spot-free rinse.
- An important new feature is "Spot-Free Rinse". This features increases revenue stream due to the fact that customers "buy" another cycle of time to get this feature. This means a potential double the income from each customer using this feature.
- Tire Cleaner and Pre-soak systems are also options that increase customer satisfaction as well as income stream.
- It is our strong recommendation that Instantaneous Tank-less water heaters also be used in place of conventional water heaters. These heaters can reduce gas costs up to 40% vs. conventional heaters. (If it rains for a week, only the pilot is using gas on these type of heaters vs. conventional heaters which heat the water column continuously rain or shine).
- Cold Climate washes should also not be without a floor heat system. These systems reduce liability and increase customer satisfaction. In-floor circulating systems are most popular. However, above-head radiant tube heaters also give the benefit of heating the floor as well as the customer.

- For floor heater sizing it is wise to also heat 3'-4' on the entrance and discharge aprons. This will reduce liability in the customer "walk" areas as they use bill changers and vendors.
- Bill changers are also a necessity. Studies have shown a minimum 10% increase in gross revenues in washes with changers. \$1 & \$5 changers are now the norm in all new wash facilities, with \$10 & \$20 optional.
- Vending products such as towels, Armorall, window cleaner and fragrance trees should not be overlooked as an added revenue source. (Average vending per wash location is approximately \* \$347 per month in total gross revenue).
- We hope this information will be beneficial to you in your investment planning. Please feel free to contact us if additional information is required.

\* **Revenue projections obtained from 2006 AutoLaundry News.**

# Car Wash Equipment Package

## Self-Serve Car Wash Package Includes the Following Per Bay:

### PUMP ROOM EQUIPMENT

- Pumping Station with Cat, Hypro, General or Giant Pumps.
- Pre-wired Electrical Panel with Starter, Transformer, Hour Meter.
- Energy-Efficient Instantaneous Water Heater (1 per bay).
- TEFC Motors, Single or Three Phase.
- Stainless Steel Wax & Soap Solenoids.
- Balanced Pressure Relief Valve for Pressure Control.
- Weep System for Freeze Prevention.
- Heavy-Gauge, Steel Frame with Baked Finish or Stainless Steel Frame and Height Adjusters.
- Entire System is Pre-Plumbed and Pre-Wired.
- Standard Pumps Rated to 3.5 GPM @ 1300 PSI or 4.0 @ 1500 PSI.

### BAY EQUIPMENT

- Stainless Steel Coin Meter with Timer, Rotary Switch & Heat Tape (If Required).
- 360 Degree Ceiling Boom of Stainless Steel & Aluminum Construction.
- Trigger Spray Wand with Swivel, Nozzle, Gun Hose & Wand Holder.
- Colorful Bay Instruction Signs.
- High Pressure Run Lines from Pumps to Ceiling Booms.
- Stainless Steel Mat Holders (4 per bay).

### Please Call for Pricing Per Bay

- 3 HP, Single Phase
- 3 HP, Three Phase
- 5 HP, Single Phase
- 5 HP, Three Phase

# Optional Equipment

## **Foam Brush Systems**

Includes stainless wall booms, brush assemblies with handles, automatic mixing tank, foam modules for each bay, stainless solenoids, air-driven transfer pump, supply run lines & instruction signs. Pre-plumbed and pre-wired.

---

## **Tire & Engine Cleaner Systems**

Includes air driven or centrifugal transfer pump with motor, automatic mixing tank, stainless solenoids and all supply run lines with fittings. Pre-plumbed and pre-wired.

---

## **Pre-Soak Cleaner Systems**

Includes air-driven or centrifugal transfer pump, automatic mixing tank, stainless solenoids, all supply run lines with fittings. Pre-plumbed and pre-wired.

---

## **Floor Heat Systems**

Includes all underfloor material, manifold boxes, thermostat, boiler and circulating pump. Also features computer schematic drawn to your specific application for ease of installation.

---

## **Spot-Free Rinse Systems**

Includes RO water production system, chlorine pre-filter, holding tank, automatic shut-off, supply run lines, pressure transfer system to all bays, stainless solenoids, bay instruction signs.

---

## **Water Softeners**

Dual Tank design with automatic regeneration on demand.

---

## **Triple Foam Protectant Systems**

Includes 3-compartment stainless steel tank with auto mixing valves, sequence controller, bay signs, run lines, bay hoses with wands and start-up chemicals.

---

## **Vacuums, Stainless Steel:**

1 Per Bay

---

## **Bill Changers,**

### **Stainless Front or Rear Load:**

Hopper Load (\$1, \$5, \$10, \$20 Options)

---

## **Soap & Wax Tanks**

Auto Stainless-Liquid, Auto Stainless-Powder or Auto Plastic-Liquid

---

## **Vending Machines**

Single Stainless With Security Bar or Multi-Vend Systems.

---

## **Bay Light Fixtures**

175 Watt Metal Halide, 3-4 per bay

---

## **Inlet Plumbing Package**

1 Per Bay

---

## **Wire Run Package**

1 Per Bay

---

***Other equipment options are Triple Foam Brush and Clear Coat Protectant Systems.***

# Typical Pump Room Layout (3-Bays)

Main Electrical Panel

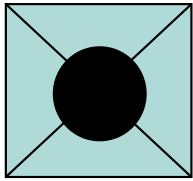

**Hot Water Supply Boiler**  
403,000 BTU  
33"W x 57"H x 26"L  
9" Flue, Gas Line 3/4"  
Water Conn. 1-1/2"  
Pump: 1/2 HP 110V  
Less than 15A

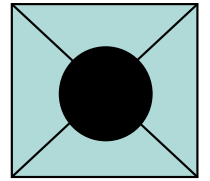

**7 Floor Heat Boiler**  
403,000 BTU  
33"W x 57"H x 26"L  
9" Flue, Gas Line 3/4"  
Water Conn. 1-1/2"  
Pump: 1/2 HP 110V  
Less than 15A

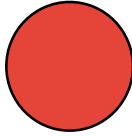

**Hot Water Supply ASME**  
Tank. 115 Gallon, 27" D x 60" H

Plumbing Connections	
See contractor specs for sizes	
<b>A</b>	Cold Soft Water Line
<b>B</b>	Hot Soft Water Line
<b>C</b>	Cold Hard Water Weep Line
<b>Dultmeier Sales</b>	
Omaha, NE 1-800-228-9666	
Pump Room Layout	
<b>3 Bay Self Serve</b>	9/10/03 DJN
Not To Scale	

**Wall Mount Air Driven Pump  
Foam Brush System** **1**  
Requires Air Line 2cfm

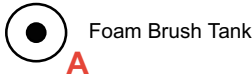

**Pre-Soak System**  
110V 1 PH 3/4 HP 13A



**Tire Cleaner System**  
Requires air line  
110V 1 PH 3/4 HP 13A



**Soap and Wax Tanks** **3**

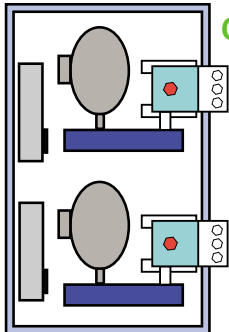

**Double Pump Station**  
(2) 5 HP 3 PH 208V 13.8A

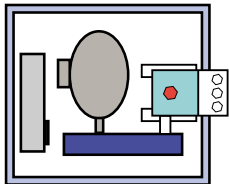

**Single Pump Station**  
(1) 5 HP 3 PH 208V 13.8A

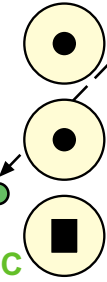

**Water Softener**  
110V less than 10A **6**

**Weep Miser**  
with Normally Open Solenoid 110V less than 10A **5a**

Water Main

**Bill Changer** (110V less than 10A) **9**

**8**

Spot Free Rinse  
Carbon Pre-filter  
12" D x 48" H



Spot Free Rinse  
Production System  
15" W X 13" D x 39" H

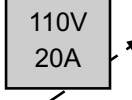

200 Gallon Spot Free  
Rinse Storage Tank  
31" D x 69" H

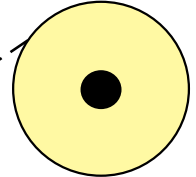

Spot Free Rinse  
Transfer System  
15" W X 13" D x 39" H

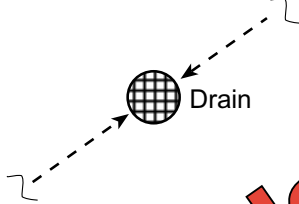
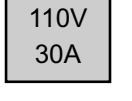

**Example**

Run 2" PVC pipe underfloor from wall to wall and stub up 12". For crossover wires, etc.

**Triple Foam Protectant**  
Wall Mount Board and Tank Assys.  
Requires air line  
3/4 HP 110V 15A

**4 Air Compressor**  
208V 5 HP 3 PH 16.5A

**Lights?**

**Vacuum Cleaners**  
110V, 15A each

Gas Main

**10 Vendors**

# Typical Pump Room Layout

(Numbers refer to 3-Bay Example shown on previous page)

- #1 **Foam Brush** (Pump System): Height: 53", Width: 24", Depth: 12". Water inlet is 3/4" FGTH. 110 Volt required. (24 volt hookup from pumping station required).
- #2 **Tire Cleaner & Pre-Soak Systems:** Height: 53", Width: 12", Depth: 24". Water inlet is 3/4" FGTH. 110 Volt required. (24 volt hookup from pumping station required).
- #3 **Soap & Wax Tanks** (Automatic-Liquid): 20 Gallon Height: 22-1/8", Diameter is 18", water inlet is 3/4" GHT. Vinyl run lines can be run from solenoids into top of the tank through the lid.
- #4 **Air Compressor:** Sized for 1 cfm per bay. 110 volt required. 3/8" connector from compressor to foam brush tire cleaner systems.
- #5 **Pump Stations:** Height: 62", Depth: 29", Width: 22" on single and 44" on double units. Hot and cold water inlets are 3/4" MGTH. Attach cold water solenoid to main with hoses supplied. Attach hot water solenoid to water heater with hoses supplied. (Note: Heaters are normally mounted above pump stations unless a boiler is being used.) Electrical requirements are as follows: 208 or 230 volt, single or three phase required for each station. Local installation will dictate requirements.
- #5a **Weep System:** Includes thermostat and solenoid. Ports are 3/8" FPT. Tap into hard water line, run separate line to solenoid valve. Plumb valve with unions (not included) and run from valve to weep inlet on pump stations, continue run to weep inlet on brush system. Attach thermostat to solenoid. 110 volt required.
- #6 **Water Softener:** Each softener includes (1) brine tank and (2) mineral tanks. 110 volt required.
- #7 **Floor Heat System:** Varies with number of bays. See separate floor heat diagram for proper hookup.
- #8 **Optional Spot-Free Rinse Systems:** Hookup will vary with specific system.
- #9 **Bill Changer:** Mounts into pump room wall, size will vary with specific model. 110 volt required.
- #10 **Vending Machines:** Mount to external walls. Height: 42", Width: 12-1/2", Depth: 5-1/2".
- #11 **Optional Pump Room Heater** (With Thermostat): 150,000 BTU, Natural Gas. 110 volt required. (Not Shown)

**\*Note:** For water line sizing, design to handle a minimum of 4 GPM per bay assuming all are running.

This is a typical pump-room layout, installations and buildings may vary causing changes to this layout to be necessary.

Dimensions and hook up specifications may change depending on which style system is purchased. Please call our car wash technical sales department to answer any questions.

# Typical Plumbing Specifications & Requirements

Plumber is responsible for the following components and labor as noted: Assume 4 GPM per Bay x number of bays for water line sizing.

Hard water supply to water softener(s) 3/4", 1" or 2" as specified. Hard plumb water softeners.

Water Heaters. From softener(s) with soft/cold water line to water heaters.

Instantaneous heaters are normally located above pumping stations. Water heaters have 3/4" MPT inlet ports. A 3/4" ball valve should be in-line between soft water supply and water heater inlet, (supplied by plumber). Required x number of bays.

From water heater outlet port (3/4" MPT) to Hot Water Solenoid on pumping station (3/4" MGHT or 3/4" FPT port).

Note: City plumbing code may require thermal relief valve to be located in this discharge line, (supplied by plumber). Required x number of bays.

Tank type water heaters will be for one central water heater source. Size and dimensions will vary with particular job. Plumbing into and out of heater to pump stations and/or automatic. See quote for model, call for specifications.

From soft/cold water line, 3/4" ball valve and supply line to Cold Water Solenoid on pumping station for each pump, 3/4" MGHT or 3/4" FPT port. (Supplied by plumber).

From soft/cold water line, 3/4" ball valve and supply line to Tire Cleaner System supply tank (if required), 3/4" FGHT port. (Supplied by plumber).

From soft/cold water line, 3/4" ball valve and supply line to Foam Brush System supply tank (if required), 3/4" FGHT port. (Supplied by plumber).

From soft/cold water line, 3/4" ball valve and supply line to Spot-Free Rinse System (if required), port size may vary. (Supplied by plumber).

From soft/cold water line, 3/4" ball valve and supply line to Automatic Soap Tank (if required), 3/4" FPT port. (Supplied by plumber).

From soft/cold water line, 3/4" ball valve and supply line to Automatic Wax Tank (if required), 3/4" FGHT port. (Supplied by plumber).

From hard/cold water line prior to water softener, 3/8" ball valve is needed to supply weep system.

From Weep Solenoid, 3/8" copper line to all pumping stations, this is the weep supply line. (This line may run right along Soft/Cold water supply line). One connection from this line will run to one connection on first pump station. From Weep Supply Line, (one) 3/8" ball valve and hard copper to back of first pump station. (Supplied by plumber), to weep check valve on pumping stations. (Supplied by Dultmeier Sales). Connection from 3/8" ball stop will be supplied by Dultmeier Sales.

From Weep Supply Line, 3/8" ball valve and supply hose to weep inlet port on Foam Brush System (3/4" FGHT). (Supplied by Plumber).

Run Discharge supply lines from pumping stations to booms in bay. (Supplied by Dultmeier Sales).

## Typical Plumbing Specifications & Requirements (cont'd)

Plumber is responsible for hook-up of floor heat boiler and all underfloor materials for floor heat system (if required). (Supplied by Dultmeier Sales). Layout print and materials will vary with job size, call for specifications.

Plumber is required to fill, bleed and leak test underfloor heat system. (Anti-freeze provided by contractor plumber or customer).

Plumber is required to activate water heaters and floor heat boiler.

Plumber or contractor is responsible for all venting (supplies and labor) and mounting of water heaters, floor heat boiler and pump room heater.

If Paloma heaters are used for hot water supply, they are to be located with the base approximately 6' from the finished floor and directly above each pump station.

Plumber or contractor is responsible for all mounting and connections for equipment room heater. (45,000 BTU input). Gas inlet is 1/2". Flue size is 4".

It is plumbers responsibility to mount, plumb and vent the trough heater if required (supplied by Dultmeier Sales). All tubing located in the ceiling trough will be installed and supplied by Dultmeier Sales.

If a High Pressure Automatic is being installed with the self-serve equipment, separate plumbing specifications and requirements are available.

### **Gas Line Requirements:**

3-4 GPM instantaneous water heaters are rated @ 178,000 BTU/hr Gas input, (1 required per bay, Natural or LP Gas as required). Note vent size on these heaters is 7". Gas connection is 1/2" FPT.

Call for specifications if tank style water heater has been quoted.

45,000 BTU/hr Gas input for pump room heater if required. Gas connection is 1/2". Vent flue is 4". Natural or LP gas as required.

Floor Heat Boiler requirements will vary with bay size, number of bays and climate: specifications can be provided after model has been specified. Natural or LP gas as required.

Trough heater may be Natural or LP Gas or Electric: Specifications can be provided after model has been specified.

**Feel free to call if you have any questions on installation or operation of this system. Car wash technical sales and service can be reached by calling 1-800-228-9666.**

*This is an honest effort to list plumbing requirements necessary in a typical carwash installation. Due to the fact that installations can and do vary, Dultmeier Sales is not stating that these are the only plumbing requirements needed for a particular job. If additions to above are required, it is not the responsibility of Dultmeier Sales.*

# Electrical Requirements (Self-Serve)

(Assuming 230 Volt Amp Draw for Pump/Motor Units)

## 230 Volt Requirements:

3 HP, Single Phase Motors, \_\_\_\_\_ Bays @ 16.8 Amps = \_\_\_\_\_  
5 HP, Single Phase Motors, \_\_\_\_\_ Bays @ 23.0 Amps = \_\_\_\_\_  
  
3 HP, Three-Phase Motors, \_\_\_\_\_ Bays @ 8.8 Amps = \_\_\_\_\_  
5 HP, Three-Phase Motors, \_\_\_\_\_ Bays @ 13.4 Amps = \_\_\_\_\_  
  
Hot & Cold, Soap & Wax Solenoids \_\_\_\_\_ Bays @ 1.5 Amps = \_\_\_\_\_  
  
Air Compressor if 5hp or larger \_\_\_\_\_ Amps = \_\_\_\_\_  
  
Total \_\_\_\_\_ Amp Draw = \_\_\_\_\_

## 110 Volt, Single Phase

**Vacuums:** \_\_\_\_\_ Vacs @ 18 Amps Per Vacuum .. = \_\_\_\_\_  
**Compressor:** 3/4 HP-6 Amps, 1-1/2 HP-9 Amps ..... = \_\_\_\_\_  
**Bill Changer:** 1.5 Amps ..... = \_\_\_\_\_  
**Inbay Lighting:** 1.5 Amps x \_\_\_\_\_ Bay Lights ..... = \_\_\_\_\_  
**Tire Cleaner Motor** (If Req'd): 10 Amps ..... = \_\_\_\_\_  
**Pre-Soak Motor** (If Req'd): 10 Amps ..... = \_\_\_\_\_  
**Foam Brush Motor** (If Req'd): 10 Amps ..... = \_\_\_\_\_  
**Floor Heat Motor** (If Req'd): 10-15 Amps ..... = \_\_\_\_\_  
**Auto Powder Soap Tank** (If Req'd): 1.5 Amps ..... = \_\_\_\_\_  
**Water Softener** (If Req'd): \_\_\_\_\_ units @ 1.0 Amps ..... = \_\_\_\_\_  
**Space Heater** (If Req'd): \_\_\_\_\_ units @ 4.0 Amps ..... = \_\_\_\_\_  
**Total:** \_\_\_\_\_ **Amp Draw:** ..... = \_\_\_\_\_

**Note:** Amp draw for outside lighting is not included and must be figured separately.

## Typical Electrical Specifications and Requirements

- All necessary components required for electrical hookup of the items shown or quoted on the enclosed sheet at the amp draws shown. This would include supplies and labor.
- Running low-voltage lines from equipment to coin meters; includes pulling of wire and labor. (Run lines are supplied in the wiring package shown on the quote sheet.)
- Mounting and wiring of all vacuums to vac islands, including supplies and labor.
- Run wires from foam brush, tire cleaner systems, etc. to main electrical panels on pumping stations. Includes supplies and labor.
- High voltage wiring from breaker box to all pump panels and from pump panels to pump motors. Includes supplies and labor.
- Electrical hookup of all electrical components on all optional items (foam brush, tire cleaner, soap tanks, water softener, bill changer, spot-free rinse, etc.). Includes supplies and labor.
- Run lines and supplies for all internal bay lights and external lot lighting. (Note: Some fixtures may be supplied in equipment bid.)
- External lot lighting if required by contractor.
- Wiring of thermostats: weep and floor heat. Electrician must be present when thermostats are activated for initial trial run.
- Wiring of motor and pump on floor heat system. Includes supplies and labor.
- If a high pressure automatic is to be installed with the self-serve equipment, separate electrical specifications and requirements are available upon request.

**Note:** due to differing installations, electrical requirements and codes may vary. This is an honest effort to describe electrical requirements of a typical car wash installation.

Conceptual Site Plan  
**Two Covered & One Outside Bay: Drive-Thru**

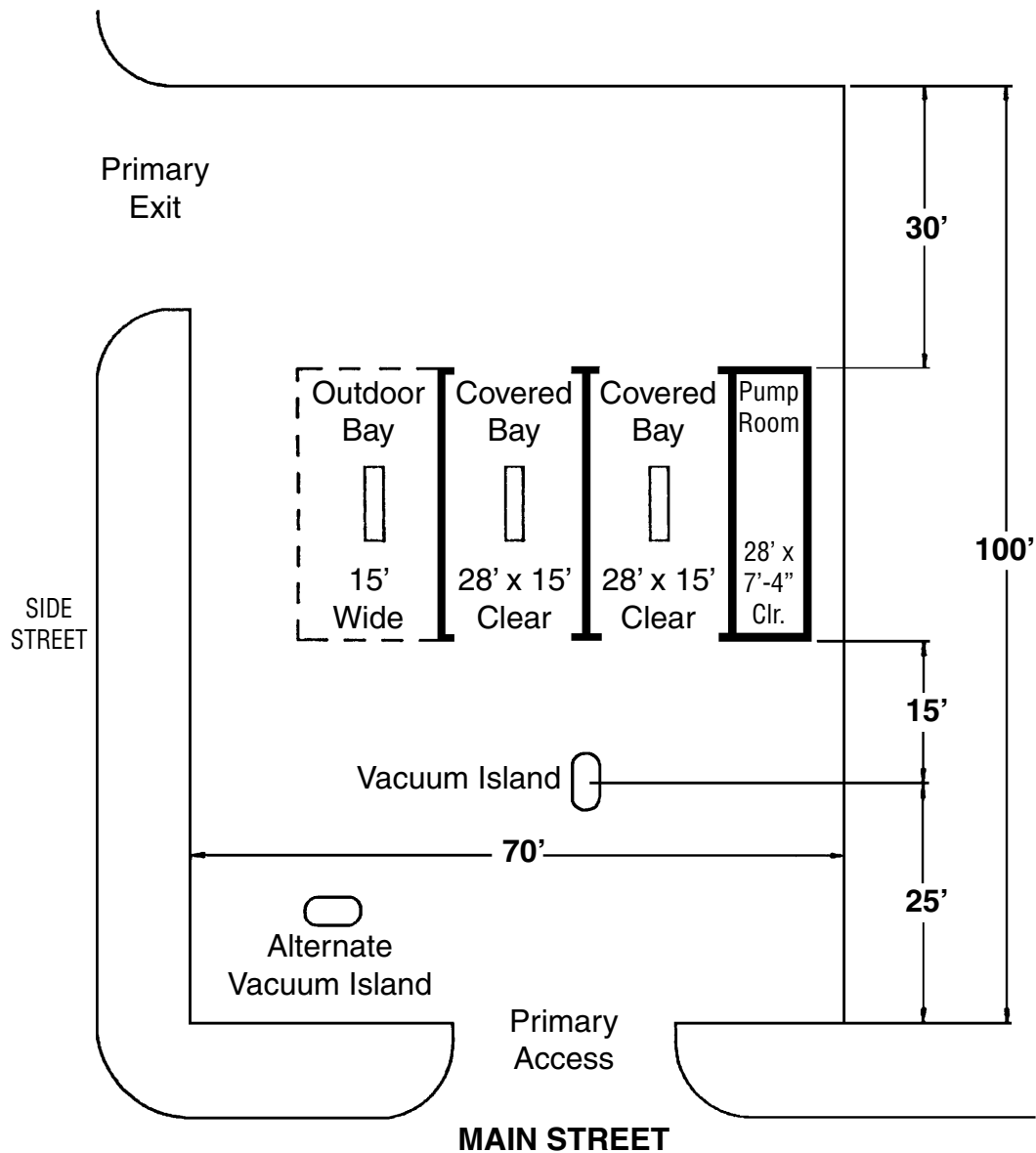

**SCALE:** 1"=20'

**NOTE:** Not for construction.

DULTMEIER ENGINEERING  
 SERVICES, INC. OMAHA  
 ©2004

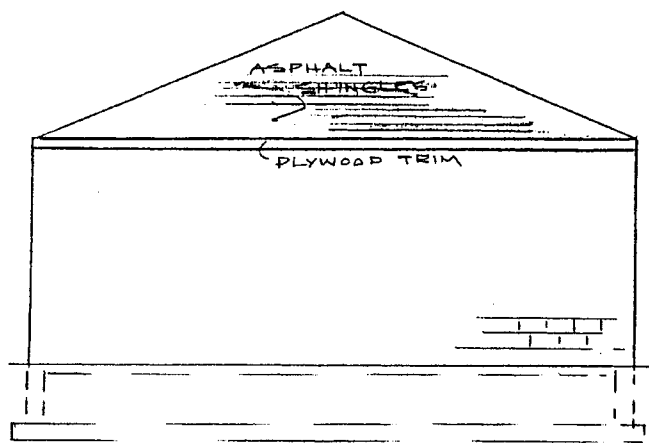

END ELEVATION

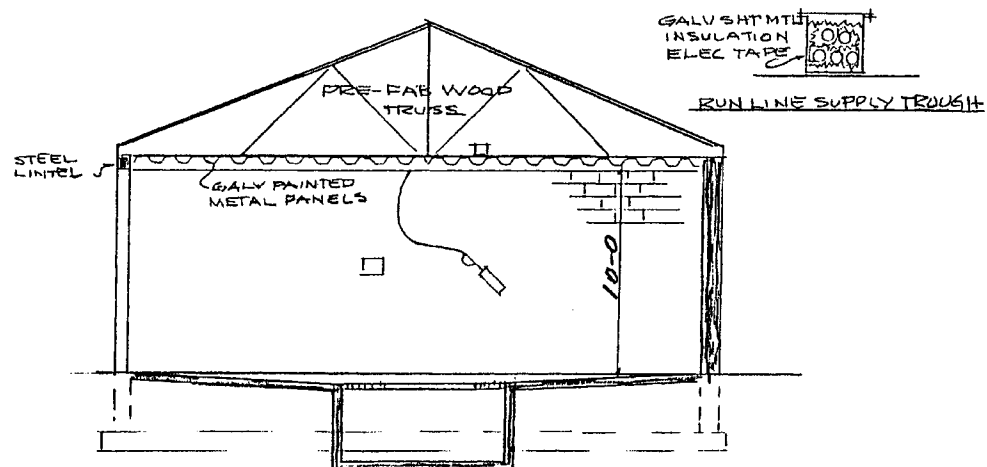

TYPICAL SECTION

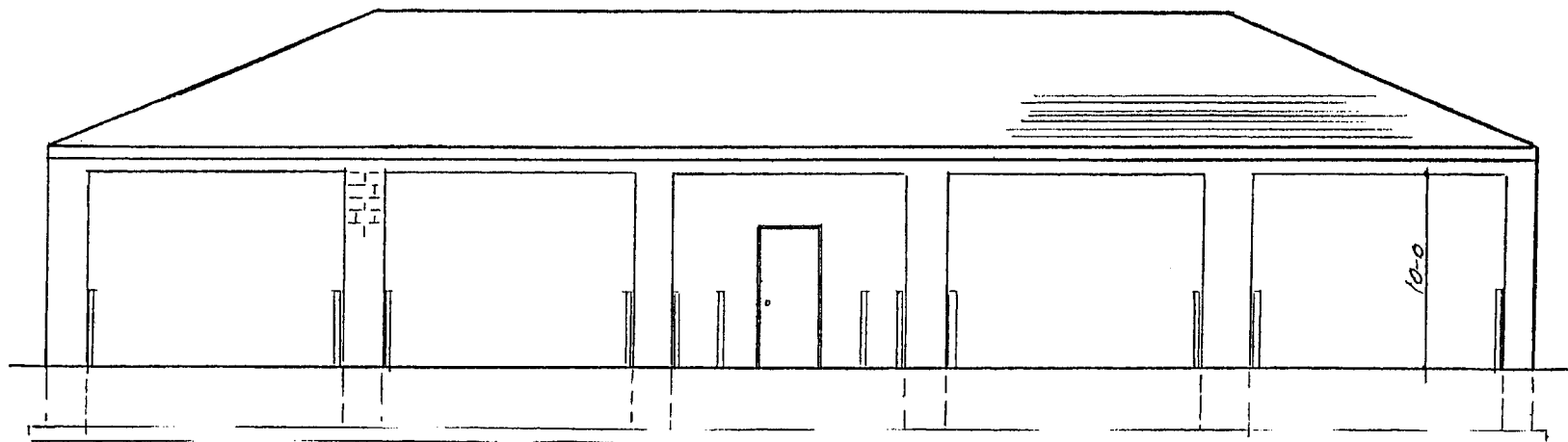

FRONT ELEVATION

DULTMEIER ENGINEERING SERVICES, INC. OMAHA ©2004

**NOTE:** Not for construction.

**DULTMEIER SALES • OMAHA, NE 1-800-228-9666 • DAVENPORT, IA 1-800-553-6975**  
 dultmeier.com • e-mail: dultmeier@dultmeier.com

# Self-Service Car Wash Systems

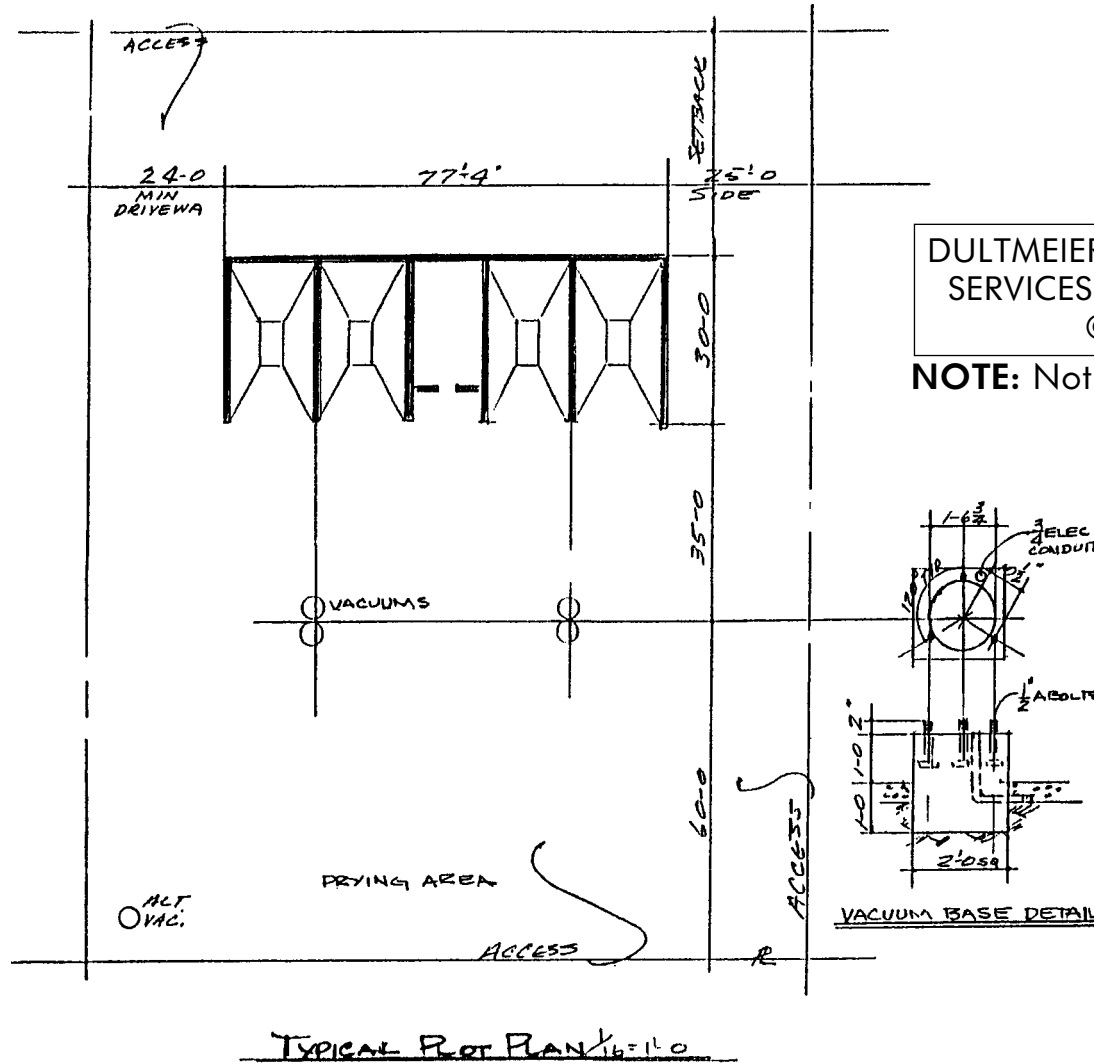

DULTMEIER ENGINEERING  
SERVICES, INC. OMAHA  
©2004

**NOTE:** Not for construction.

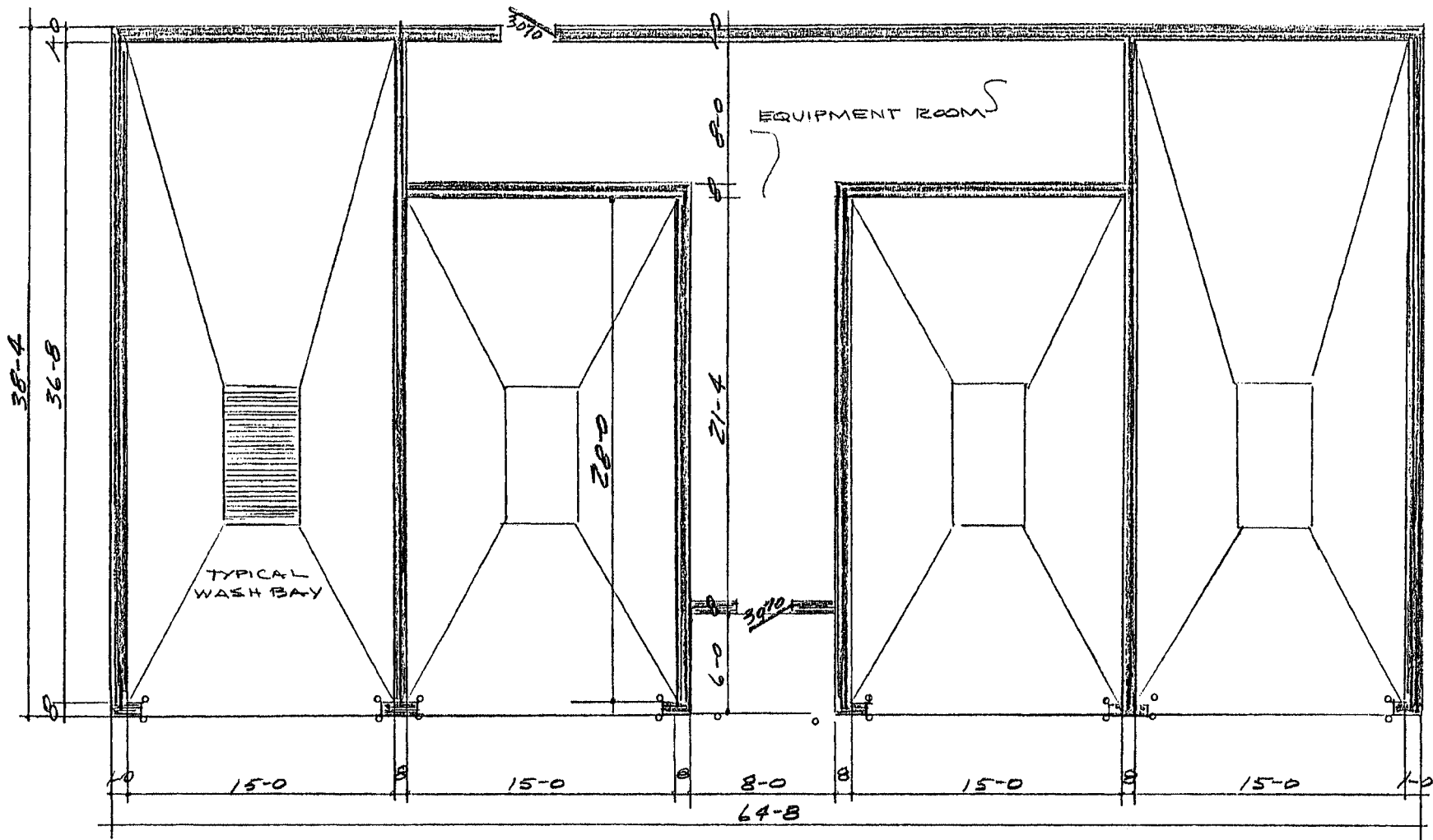

ALTERNATE PLAN

DULTMEIER ENGINEERING SERVICES, INC. OMAHA ©2004

**NOTE:** Not for construction.

DULTMEIER SALES • OMAHA, NE 1-800-228-9666 • DAVENPORT, IA 1-800-553-6975  
 dultmeier.com • e-mail: dultmeier@dultmeier.com

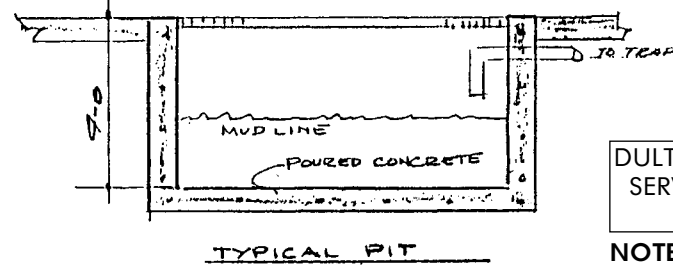
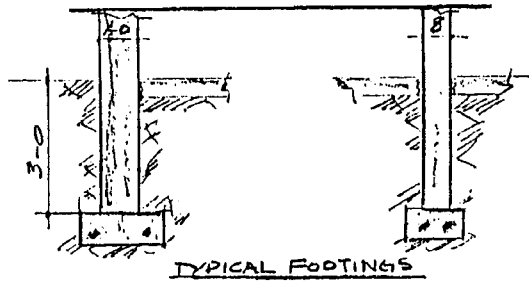

DULTMEIER ENGINEERING  
SERVICES, INC. OMAHA  
©2004

NOTE: Not for construction.

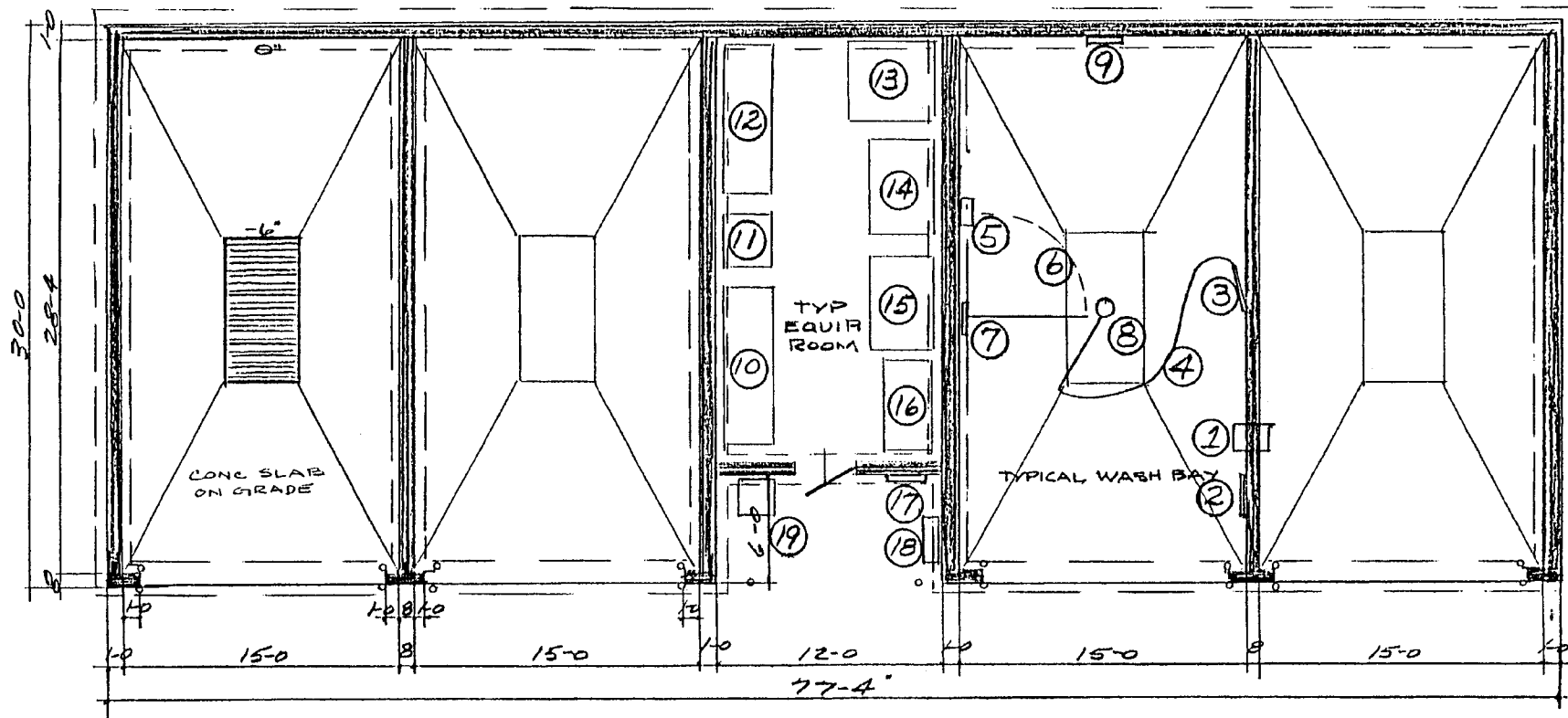

TYPICAL FLOOR PLAN

# **Dultmeier Car Wash Equipment Locations**

*Numbers Reference Previous Page*

## **Inbay Equipment**

- #1 Stainless steel coin meter with drop-style coin mechanism. Includes stainless money box with lock.
- #2 Bay instruction sign:  
Length - 37", Width - 25".
- #3 Wand holder for spray gun: 2"  
Square steel tubing: length - 19".
- #4 Spray gun assembly with trigger gun, extension, swivel, hose, nozzle.
- #5 Poly brush bucket mounted at floor level.
- #6 Foam brush assembly with brush head, handle, swivel and hose.
- #7 Stainless steel, 180 degree wall boom for brush assembly. Overall length is 7".
- #8 Overhead ceiling boom for spray gun assembly. Overall length is 6'.  
Mount in center of bay area.
- #9 Mat holders: 4 per bay.

## **Pump Room Equipment**

- #10 Pump table for up to 4 bays.  
8' length x 3' depth. Two tables required if more than 4 bays.
- #11 Tire cleaner system if required.
- #12 Optional pump table if required.
- #13 Water softener system.
- #14 Floor heat system.
- #15 Foam brush system.
- #16 Optional work table.
- #17 Bill changer if required.
- #18 Vending machines.
- #19 Optional pop machine.

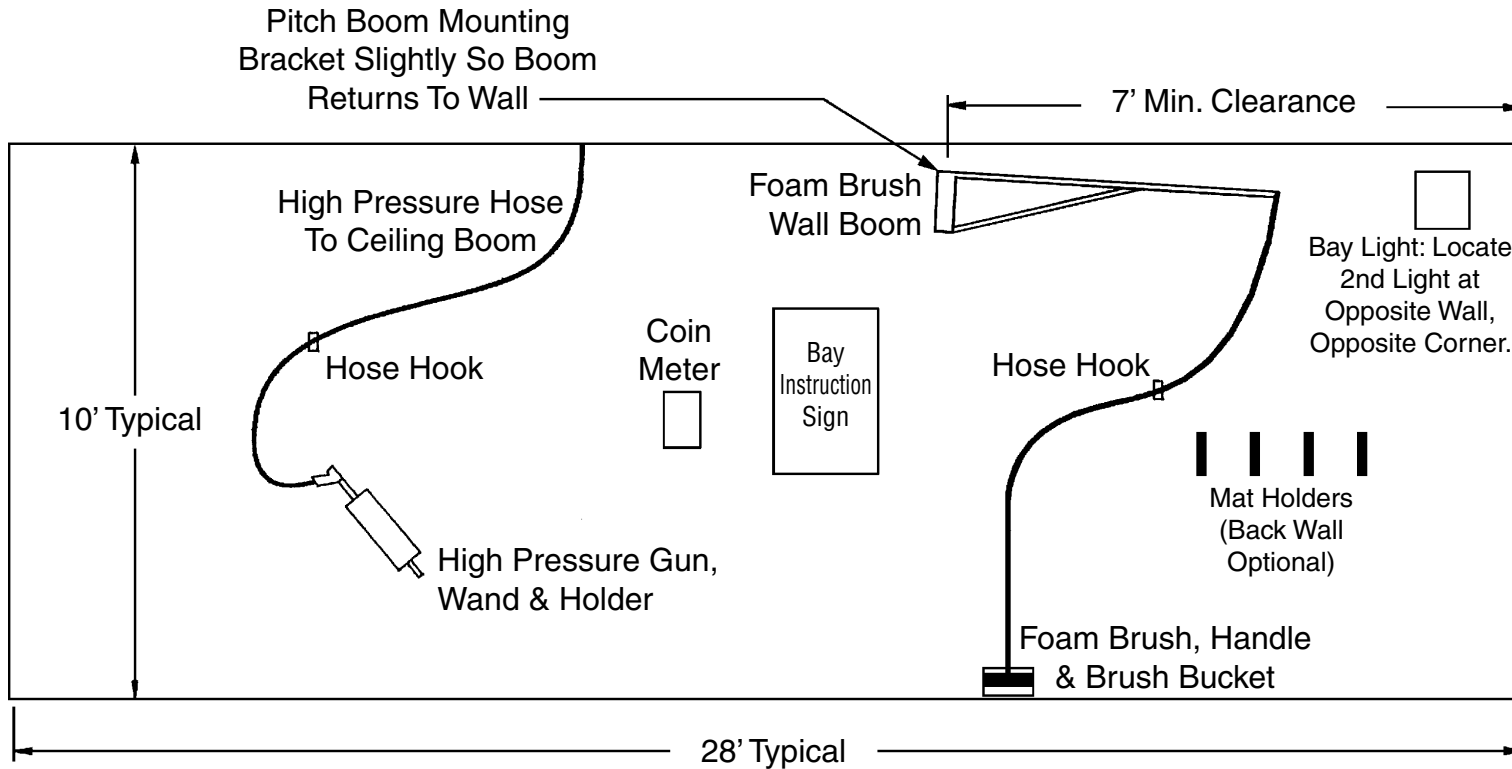

## Equipment Layout Typical Bay Sidewall

(Not to Scale)

DULTMEIER ENGINEERING  
SERVICES, INC. OMAHA  
©2004

Conceptual Site Plan  
**Two Inside & One Outside Bay: Drive-In, Back-Out**

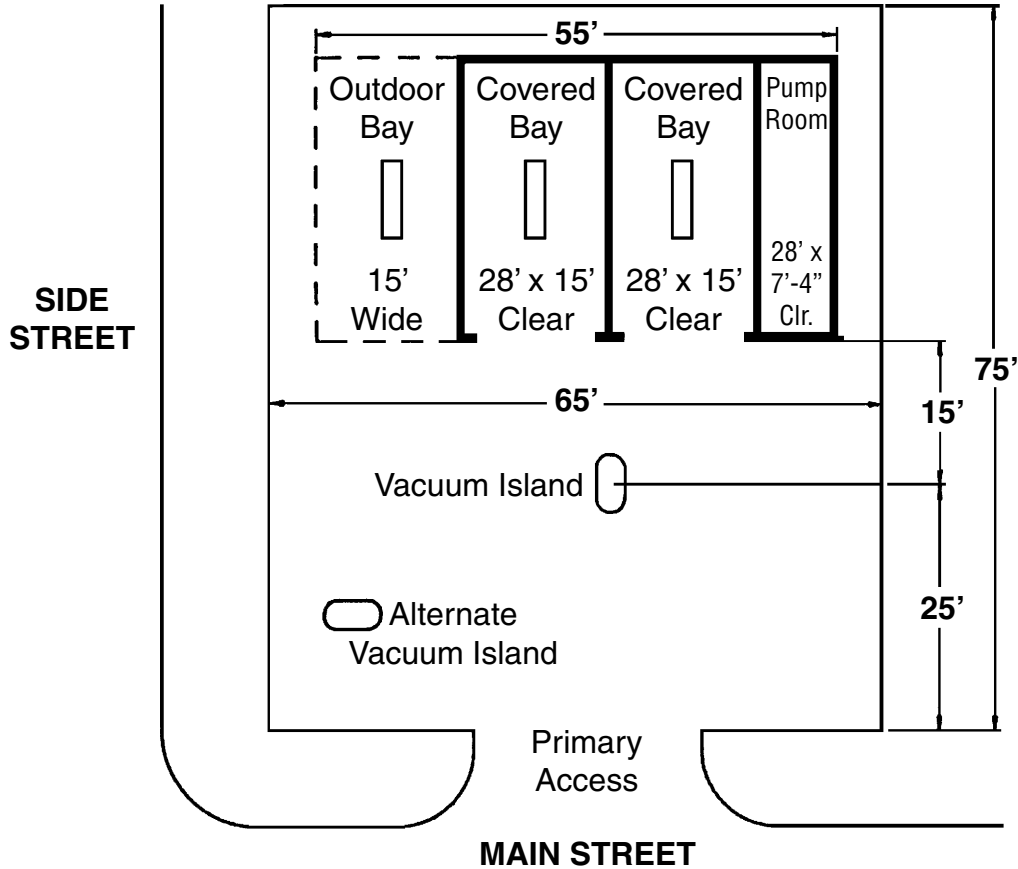

**SCALE:** 1"=20'

**NOTE:** Not for construction.

DULTMEIER ENGINEERING  
SERVICES, INC. OMAHA  
©2004

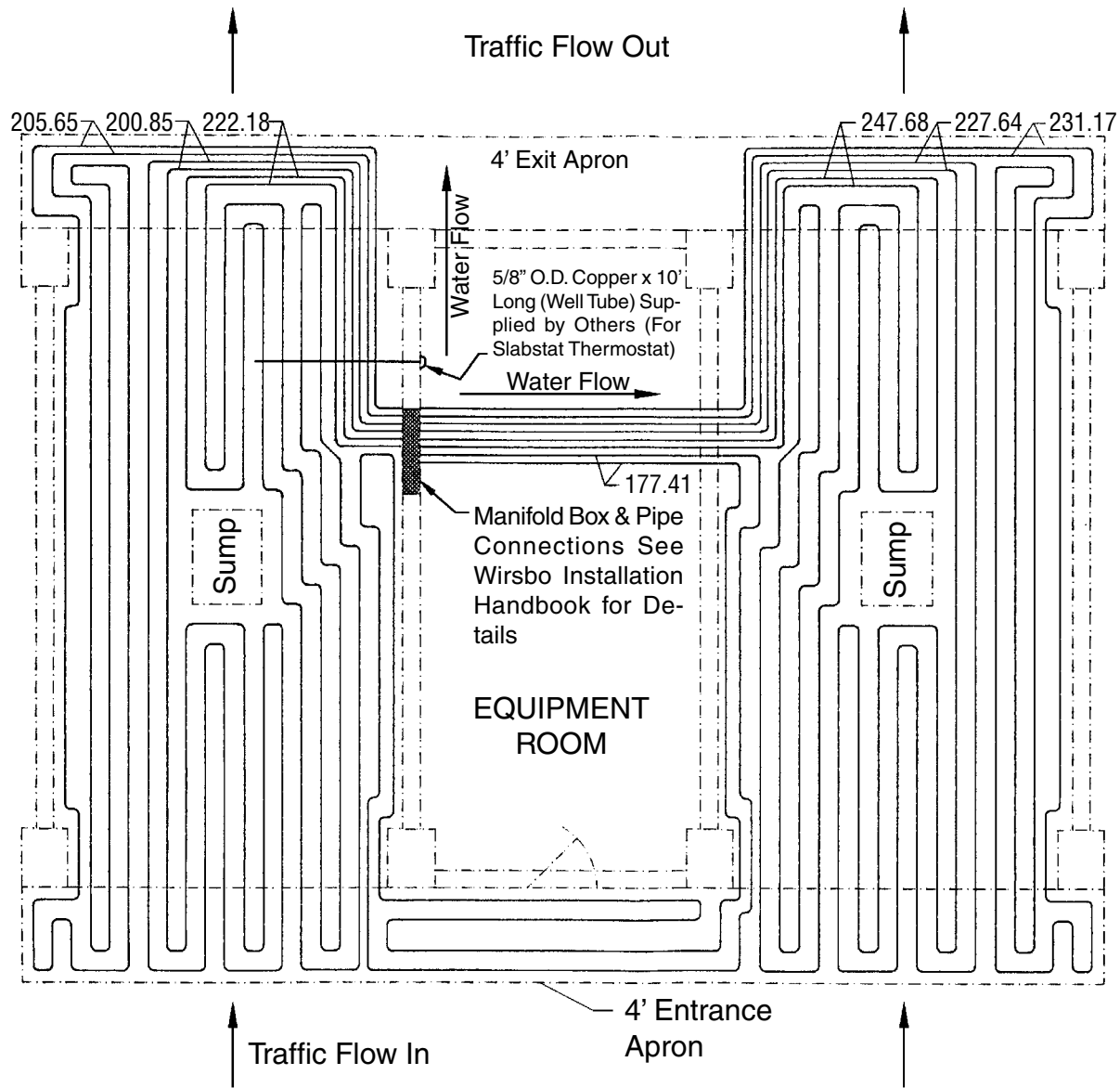

**Plan:  
Car Wash  
2-Bay  
Floor Heat  
System**  
(Not to Scale)

DULTMEIER ENGINEERING  
SERVICES, INC. OMAHA  
©2004



# Run Line Trough

© Dultmeier Sales 2004

Build trough on either side of equipment room down center of building above ceiling mount booms. Fix 3/8" MPT pipe nipple from boom into trough. All low pressure system run line manifolds should tee into high pressure line as close to boom as possible.

Trough may also be made using PVC pipe with loop returned to equipment room. Fan is available for direct mount on 4" PVC to force warm air through loop. Windows should be cut in pipe where connections are made.

## Wood Trough

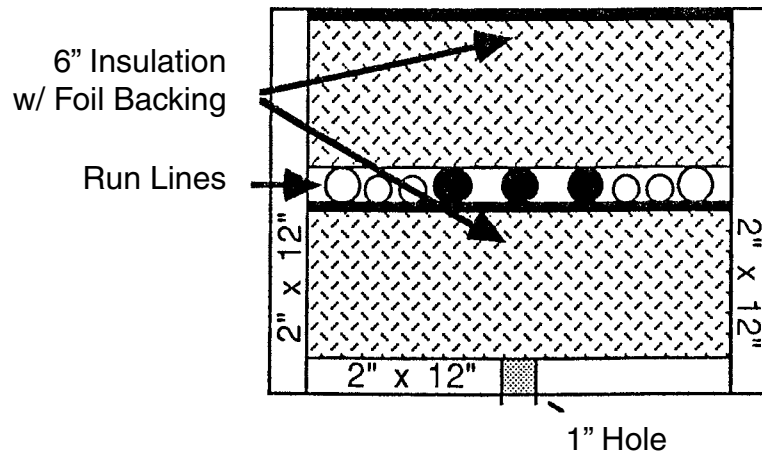

### Optional:

- Run heated loop with other run lines.
- Line inside of wood with 1" styrofoam.
- Space drain holes along bottom of trough.

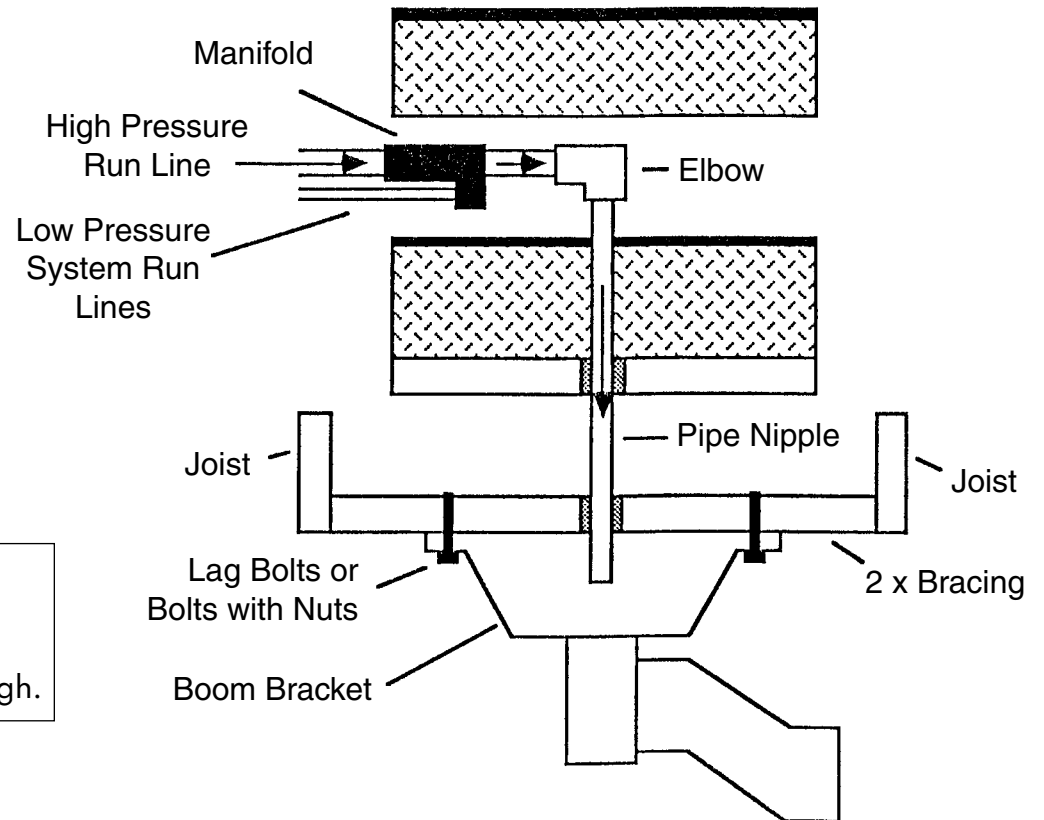



# Sand Interceptor/Pit Detail

© Dultmeier Sales 2004

Not For  
Construction

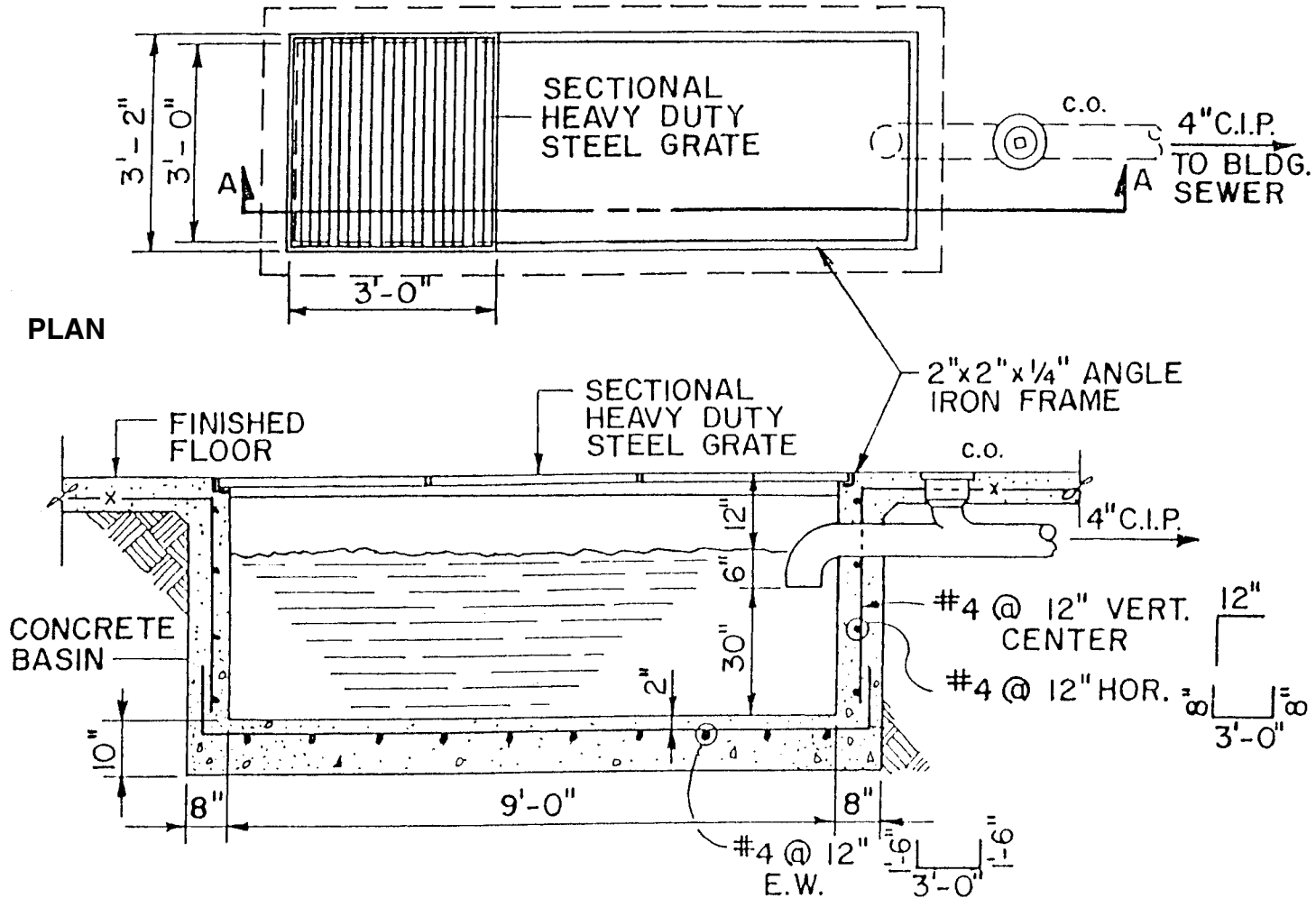



## **Advantages of Using Dultmeier Sales**

- Quality, name brand pumps, valves & components
- All systems are made to order - this means we can custom build to meet your needs.
- Technical Sales Support on equipment design and operation.
- Over 20 years of manufacturing experience in the car wash and truck wash industries.
- Cold weather Freeze Prevention is standard on all equipment.
- Service and production staff on hand for help with installations or trouble shooting needs.
- Large inventory from over 350 supply lines means our product offering is vastly superior to our competitors, this means more variety in system design.
- Quick turnaround times on equipment, parts and supplies means less down time for our customers.

***Give Dultmeier a try. We think you'll like what you see.***