



# High Capacity Hydraulic Driven Centrifugal Pump

## FMC-200-HYD-310



- Suction 2" Discharge 1-1/2"
- Recommended for use on Open Center Hydraulic Systems from 16 to 25 GPM
- Integral Needle Valve bypasses up to 9 GPM on Open Center Systems
- Standard Viton® Carbon/Ceramic seal or Optional Severe Duty Silicon Carbide Mechanical Seal
- Chemical Resistant Valox® or Optional Cast Iron Impeller
- Stainless Steel Shaft and Wear Ring

### PERFORMANCE CHART

SHUT-OFF 0 GPM	40 GPM	80 GPM	120 GPM	160 GPM	200 GPM
80 PSI	76 PSI	68 PSI	57 PSI	43 PSI	-
60 PSI	56 PSI	50 PSI	40 PSI	-	-

Use the SHUT-OFF pressure of your spraying system to determine which line of data applies. The hydraulic system input pressure and flow will vary within the chart. Contact factory for more data.

**MAXIMUM SHUT-OFF PRESSURE - 80 PSI**

Valox® is a registered trademark of GE Plastics.  
Viton® is a registered trademark of DuPont Dow Elastomers.

### DIMENSIONS

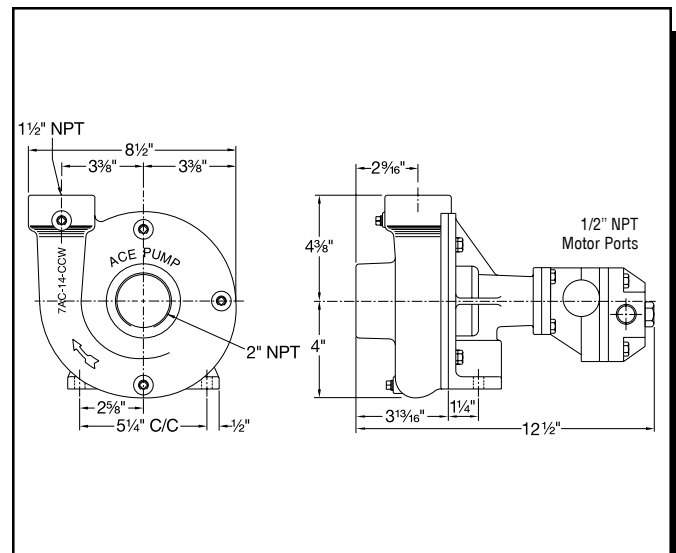



# FMC-200-HYD-310

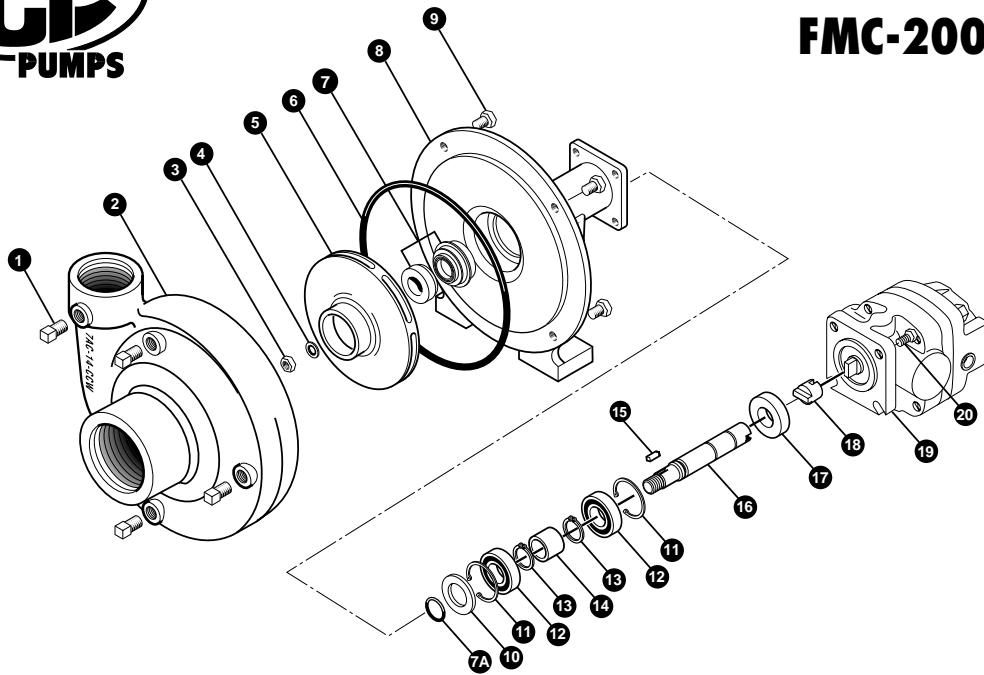

REF. #	PART NUMBER	EDP #	DESCRIPTION	REQ.
1	41110	41110	Pipe plug	4
1	41120	41120	Pipe plug, stainless steel (optional)	4
2	7AC-14-CCW	41526	Volute, 2" x 1-1/2"	1
3	BAC-23-A	40391	Nut, 3/8" NF, cad plated	1
4	BAC-24-HYD-SS	40400	Washer, 3/8" star, stainless steel	1
5	BAC-26-200-P	40434	Impeller, with extended keyway, cast iron	1
5	BAC-26-200-CI	40433	Impeller,with extended keyway, cast iron (date code E-9 and up)	1
5	BAC-26-HYD-200-CI	41525	Impeller, cast iron, keyway (obsolete 6/99)	1
*6	BAC-4	40010	Gasket, 4 hole	1
*6	BAC-4A	40005	O-ring, body seal, effective April 1996	1
*7	BAC-7V	40151	Seal, mechanical, Viton (includes 40160 O-Ring)	1
7	BAC-7SC	40152	Seal, mechanical, silicon carbide (includes 40160 O-Ring) (optional)	1
7A	40160	40160	O-ring, shaft seal	1
8	BAC-14-HYD-300	40301	Mounting frame (for -300 series hydraulic motor)	1
9	40950	40950	Cap screw, 3/8" NC x 3/4" hex head	4
9	40930	40930	Cap screw, 3/8" NC x 3/4" hex head, stainless steel (optional)	4
10	BAC-54	41130	Slinger	1
11	BAC-33	40810	Snap ring, internal, BAC-14 mounting frame	2
12	BAC-37	40870	Ball Bearing, sealed, BAC-6 shaft	2
13	BAC-32	40790	Snap ring, external, BAC-6 shaft	2
14	BAC-32-S	40795	Spacer for BAC-6 shaft	1
15	BAC-25	40425	Key, 1/8" x 1/8" x 13/16", extended keyway (date code E-9 and up)	1
15	BACH-25	40420	Key, 1/8" x 1/8" x 1/2"(obsolete 6/99)	1
16	BAC-6-HYD-200-SS	40063	Shaft, extended keyway, tang, stainless steel(date code E-9 and up)	1
16	BAC-6-HYD-SS	40061	Shaft, 5/8" dia., keyway, tang slot, stainless (optional)(obsolete 6/99)	1
17	S300	40162	Seal support spacer for 300 Series HYD motor, effective 04/01	1
18	BAC-76-HYD	41380	Coupling for hydraulic motor	1
19	BAC-75-HYD-310	41378	Hydraulic motor, 16 GPM	1
20	41330	41330	Cap screw, 5/16" N. C. x 3/4" hex head, motor to pump	4
#	RK-FMC	52700	Repair kit for FMC series pump	-
#	RK-BAC-75-HYD-310	41379	Repair kit for 310 motor	-
#	RK-BAC-75-HYD-300-L	41362	Repair kit for 310-L motor, effective 04/01	-

\* Items included in pump repair kit.

**Ace Pump Corporation • P.O. Box 13187 - 1650 Channel Avenue • Memphis, TN 38113**  
**www.AcePumps.com • Phone: 901-948-8514 • Fax: 901-774-6147**

Ace Form # FMC-200-HYD-310  
 Revised 04/01