

- Installation
- Operation
- Repair
- Parts

RollerPRO® 8900 Series

8-Roller

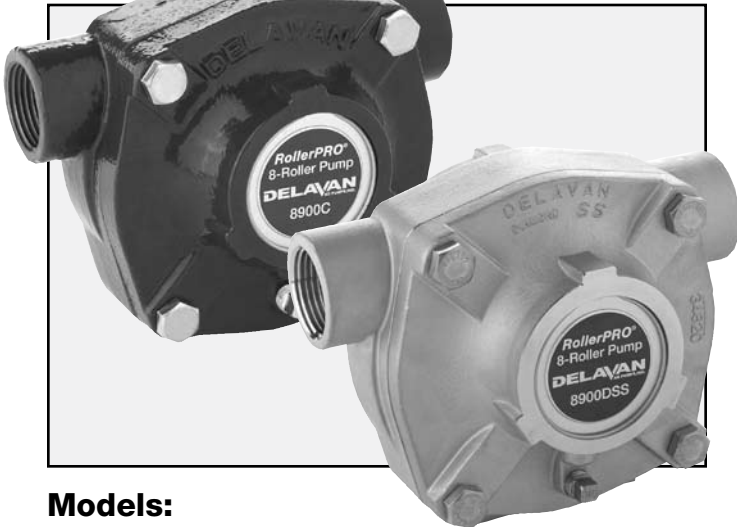

Materials of Construction

Housing: Cast Iron (blue epoxy paint) or Diamond™ Stainless Steel

Shaft Seals: Viton cartridge type lip seals

Seal Ring: Viton

Shaft & Rotor:

Cast Iron: Extra-fine finish 404 SST

Diamond™ Stainless Steel: Extra-fine finish 416 SST

Bearings: Permanently-lubricated, heavy-duty sealed bearings

Dimensions

(in)

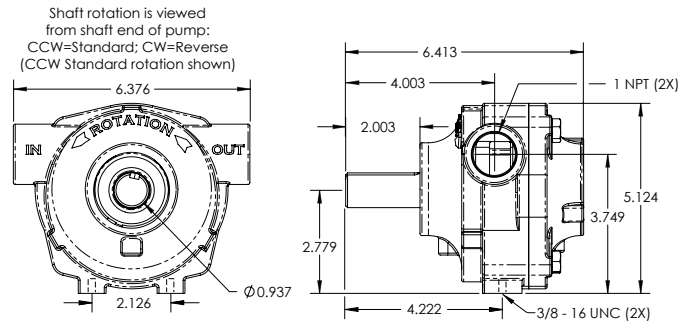

Models:

- 8900C** **Cast Iron (Blue Epoxy Paint)**
- 8900C-R** **Cast Iron (Blue Epoxy Paint)**
(Reverse Rotation)
- 8900DSS** **Diamond™ Stainless Steel**
- 8900DSS-R** **Diamond™ Stainless Steel**
(Reverse Rotation)

Specifications

Number of Rollers	8		
Rollers Diameter	11/16"		
Flow (GPM) @ Specified Pressure and Speed	RPM		
PSIG	540	850	1000
0	13.0	20.2	24.0
20	12.4	19.8	23.2
40	11.6	19.1	22.4
100	10.6	18.6	21.8
200	8.9	15.7	18.0
300	7.0	14.0	17.1
Max Pressure (PSIG)	300		
Ports	1" NPT		
Shaft Diameter	15/16"		
Dimensions – W x D (in)	6-1/4" x 4-1/2"		
Weight – lb (kg)	14 (30.8)		

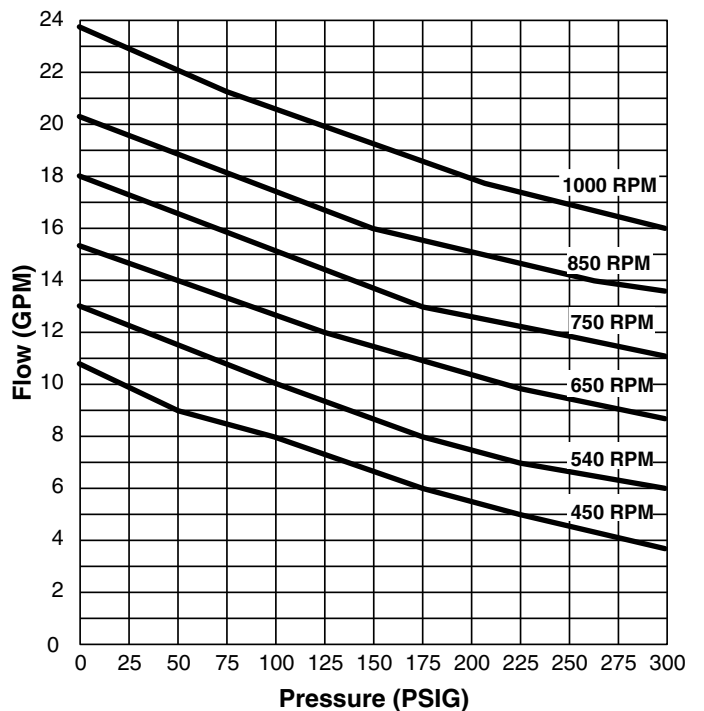

Delavan *RollerPRO*[®]

Tractor PTO Installation

1. Secure the PTO coupling to the pump shaft by sliding the coupling as far forward as possible without touching the bearing shield and tightening the set screws down on the key of the pump shaft. Slide coupling onto PTO shaft and secure by pulling collar back on PTO quick coupler, sliding onto PTO shaft and locking into place.
2. Check pump rotation. An arrow on the pump indicates proper rotation direction.
3. To keep the pump from rotating with the shaft, set a torque arm and short length of chain. Bolt one end of the chain to the torque arm and secure the other to a stationary part of the tractor. Be sure the chain is at a point directly above or below the torque arm. Fastening torque chain to a point forward or backward from pump center will create a bending force on pump. Do not fasten pump rigidly to the tractor.
4. With the pump in position, connect the inlet hose to the “IN” port and the discharge hose to the “OUT” port. Make sure the inlet hose connection is tight. A loose connection will permit air to be drawn in and the pump will not prime itself. Use at least a 3/4” diameter hose on the inlet line.

Engine Installation

The pump base can be mounted on a frame and aligned for either direct-drive or belt and pulley drive. When mounting for direct-drive, be sure pump and engine shafts are in alignment. A flexible drive coupling will compensate for fractional misalignment. When mounting for pulley drive, be sure the engine and pump shafts are parallel. Align pulleys and keep them as close to the shaft bearings as possible. Please review pump maximum pump RPM specification.

Operation

1. With a clear inlet line and open discharge line, the pump should displace liquid within 15 seconds. A squirt of oil in the inlet side of the pump before starting will accelerate priming action.
2. Never run the pump dry. Excessive heat will damage rollers and seals.
3. Do not pump abrasive white wash, paints or other abrasive liquids.
4. Do not use rusty supply barrels or sandy water.
5. Do not close the discharge line of the pump while it is running unless a means of bypassing the liquid has been installed. A simple relief or bypass valve can be easily installed in the discharge side.

Maximum Recommended Operating Temperature:
140°F (60°C)

Maintenance

Your Delavan pump is equipped with permanently lubricated bearings. They do not require further lubrication.

AFTER SPRAYING — Thoroughly flush the pump with clear water or use a solution of approximately one cup of ammonia in 10 gallons of water. This will dissolve most residue remaining in the pump. Squirt a light oil in the pump and rotate to cover the inner surfaces with a protective film.

STORAGE. If the pump is to be out of service for several days or stored, flush pump with clear water or use a solution of one cup of ammonia in 10 gallons of water. Then pump a 50 percent permanent antifreeze solution through the pump. Plug ports.

Caution: Do not use gasoline, kerosene, or fuel oil.
Cast iron not recommended for Round Up[®].

Servicing & Repair

Exclusive, patent pending Delavan RollerPRO[®] pumps are the only field-serviceable pump on the market! The only tool required to service RollerPRO[®] pump is a wrench. The pump remains mounted on drive shaft – no plumbing disassembly is required. Pump servicing takes about 3 minutes:

1. Loosen and remove four bolts on end plate of pump, and slide off
2. Replace rollers (and other parts from RollerPRO Repair kit as necessary– see next page for kit details)
3. Slide on end plate, tighten bolts and go!

Roller Pumps

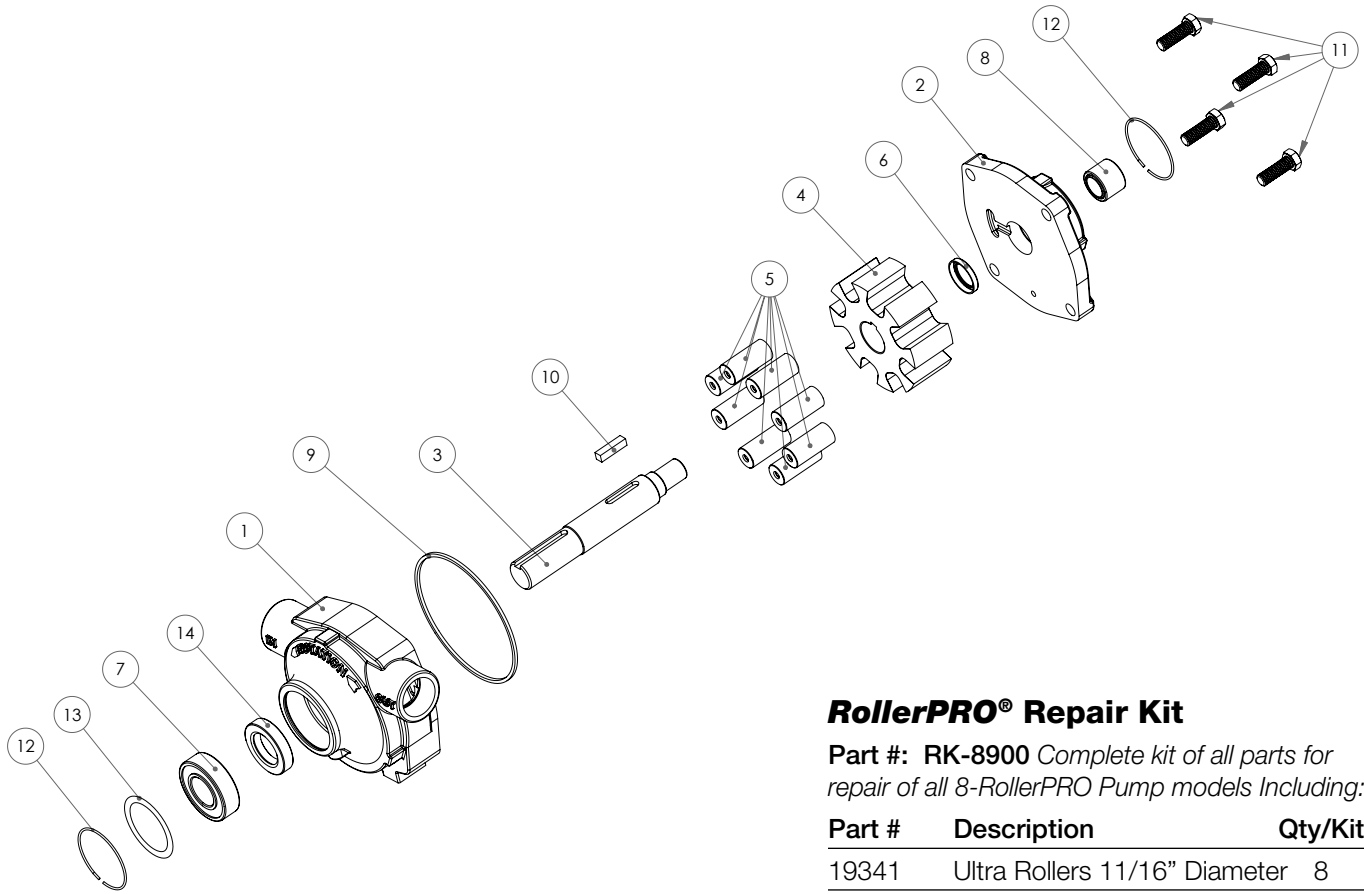

8900 Series RollerPRO® Pump Parts

Ref #	Part#	Description	Qty/ Pump
1	—	Body	1
2	—	End Plate	1
3	31810	Shaft	1
4	36801	8-Roller Rotor for Cast Iron Models	1
	36802	8-Roller Rotor for Diamond SS Models	
5	19341	Ultra Rollers 11/16" Diameter	8
6	37801	Shaft Seal	1
7	16228	Ball Bearing	1
8	38801	Needle Bearing	1
9	24829	Seal Ring	1
10	40801	Shaft Key	1
11	—	Hex Head Screw- 3/8-16UNC x 1-1/8"	4
12	15334	Snap Ring	2
13		Name Plate:	1
	40810-1	8900C (Cast Iron)	
	40810-2	8900C-R (Cast Iron Reverse Rotation)	
	40810-3	8900DSS (Diamond Stainless Steel)	
	40810-4	8900DSS-R (Diamond Stainless Steel Reverse Rotation)	
14	47927	Lip Seal	1

RollerPRO® Repair Kit

Part #: RK-8900 Complete kit of all parts for repair of all 8-RollerPRO Pump models Including:

Part #	Description	Qty/Kit
19341	Ultra Rollers 11/16" Diameter	8
37801	Shaft Seal	1
47927	Lip Seal	1
24819	Seal Ring	1
40801	Shaft Key	1

Accessories

Torque Bar and Chain **Part #: 33680**

Required to anchor PTO-mounted pumps in order to keep pump from rotating with the shaft

Coupler **Part #: 35735**

For 1-3/8" diameter PTO; 15/16" pump shaft; 540 RPM; forged steel body, nylon collar*

Coupler **Part #: 46814-3**

For 1-3/8" diameter PTO; 15/16" pump shaft; dual speed 540-1000 RPM; corrosion-resistant cast aluminum, nylon collar*

Coupler **Part #: 35979**

For 1-3/8" diameter PTO; 15/16" pump shaft; 1000 RPM; forged steel body, nylon collar*

*Mounting hardware included

Troubleshooting Guide

Problem	Causes and Remedies
No pressure or no capacity	Inlet line not fully immersed in tank, or low tank level.
	Pump not properly primed.
	Clogged inlet strainer.
	Inlet line air leaks. Use plumber's joint compound or Teflon tape. Tighten all connections. Check hoses for cracks or pin holes.
Pump runs, but low pressure and capacity	Inlet line blocked or hose collapsed.
	Pump is air-bound. Check for dry tank, or "traps" in the line. Try removing one nozzle until pump starts priming.
	Worn and leaking seals. Replace.
	Pump turning in wrong direction. (A reverse direction pump will not work on a tractor PTO).
Pump pressure good, but low output through the nozzles	Inlet line and fittings partially blocked or too small. Hose kinked
	Worn rollers. Replace with new (see parts list).
	Clogged inlet strainer.
Excessive noise or vibration	Nozzle orifices too small. Install larger sizes.
	Outlet line too small or blocked.
	Bypass partially open. Close it.
Impossible to rotate shaft	Possible loose coupler...bent or damaged shaft.
	Excessive PTO speed...1200 rpm maximum.
	Inlet line leaks or clogged strainer
Excessive noise or vibration	Worn rollers. Replace with new.
	Corrosion or foreign object in pump. Disassemble and thoroughly clean all parts. Replace worn parts. See section on Maintenance.

Warranty

Delavan warrants RollerPRO Series Pumps for a period of one year from date of manufacture.

All products sold by Delavan are warranted only to purchasers from Delavan for resale or for use in purchasers' own business or original equipment manufacture, against defects in workmanship or materials under normal use, maintenance and service (rental use excluded).

The sole and exclusive obligation of Delavan under this or any implied warranty shall be to replace or, at its option, to repair, without charge, any product which is determined by Delavan to be defective in workmanship or materials after the product is returned to the Delavan factory*, shipping costs prepaid.

In no event shall Delavan be liable to any person for indirect or consequential damages or for injury or commercial loss resulting from any use or inability to use any Delavan product. Delavan expressly negates any other warranty, express or implied, including any warranty of merchantability or fitness for a particular purpose, or arising from any course of dealing or custom or usage of trade.

No person, including any dealer or representative of Delavan, is authorized to make any representation or warranty on behalf of Delavan in addition to or inconsistent with these provisions. Purchasers to whom these provisions apply agree to hold Delavan harmless from claims by their customers in excess of the obligations of Delavan expressly set forth herein.

* Important Return Safety Instructions

Since pumps can contain residues of toxic chemicals the following steps are necessary to protect all the people who handle return shipments, and to help pinpoint the reason for the breakdown. When you return your pump for warranty or repair, you must always do the following:

1. Flush chemical residue from the pump (best done in the field).
2. Tag pump with type of chemicals having been sprayed.
3. Include complete description of operation problem, such as how pump was used, symptoms of malfunction, etc.



1228 Chestnut Avenue, Minneapolis, MN 55403
 Toll Free: 1-866-DELAVAN (335-2826) PH: 612-333-3189
 Toll Free Fax: 1-888-726-5906 Fax: 612-333-3231
 Website: delavanagpumps.com