



DOSATRON®

WATER POWERED DOSING TECHNOLOGY

SCHEMATICS

Dosatron Liquid Dispenser **Model # D25RE10 – 8.8 GPM**

1:33 – 1:10

4.3 – 57 PSI

$\frac{3}{4}$ " NPT connection

Suggested Installation:

200 mesh/80 micron water filter prior to unit

One-way check valve downstream from unit for water hammer protection

Suggested Maintenance Interval:

Replace injection seals every 12 months

Replace Maintenance Kit components every 3 to 4 years

(Kit references available on Page 1)

DOSATRON SALES & SERVICE - NORTH & CENTRAL AMERICA

Dosatron International, Inc.

Phone: 727-443-5404 Service: (800) 523-8499

Fax: 727-447-0591

www.dosatronUSA.com

D25RE10
11/03

8.8 GPM - 1:33 - 1:10
4.3 - 57 psi

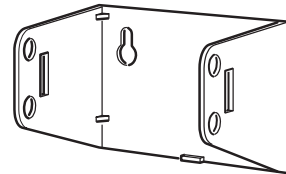
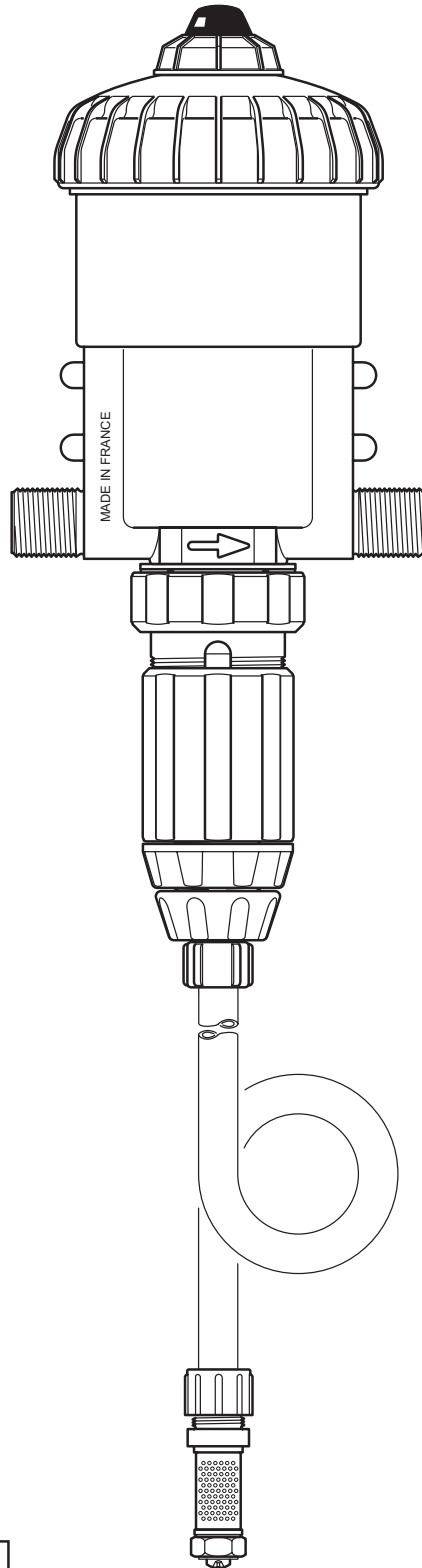

MKD25RE10 Maintenance Kit

ED2510 Injection Seal Kit

D25RE10

11/03

8.8 GPM - 1:33 - 1:10
4.3 - 57 psi

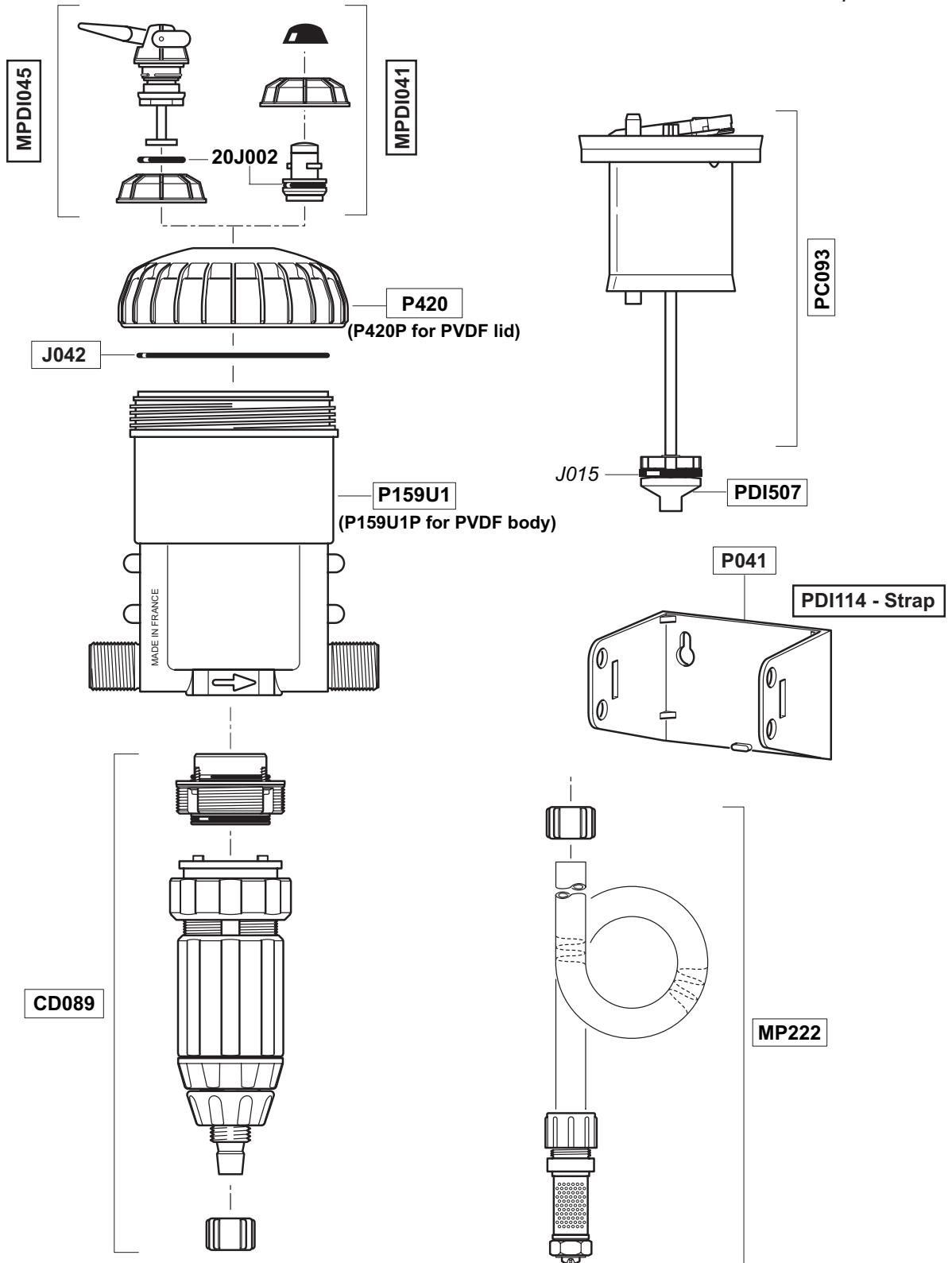

D25RE10

11/03

8.8 GPM - 1:33 - 1:10
4.3 - 57 psi

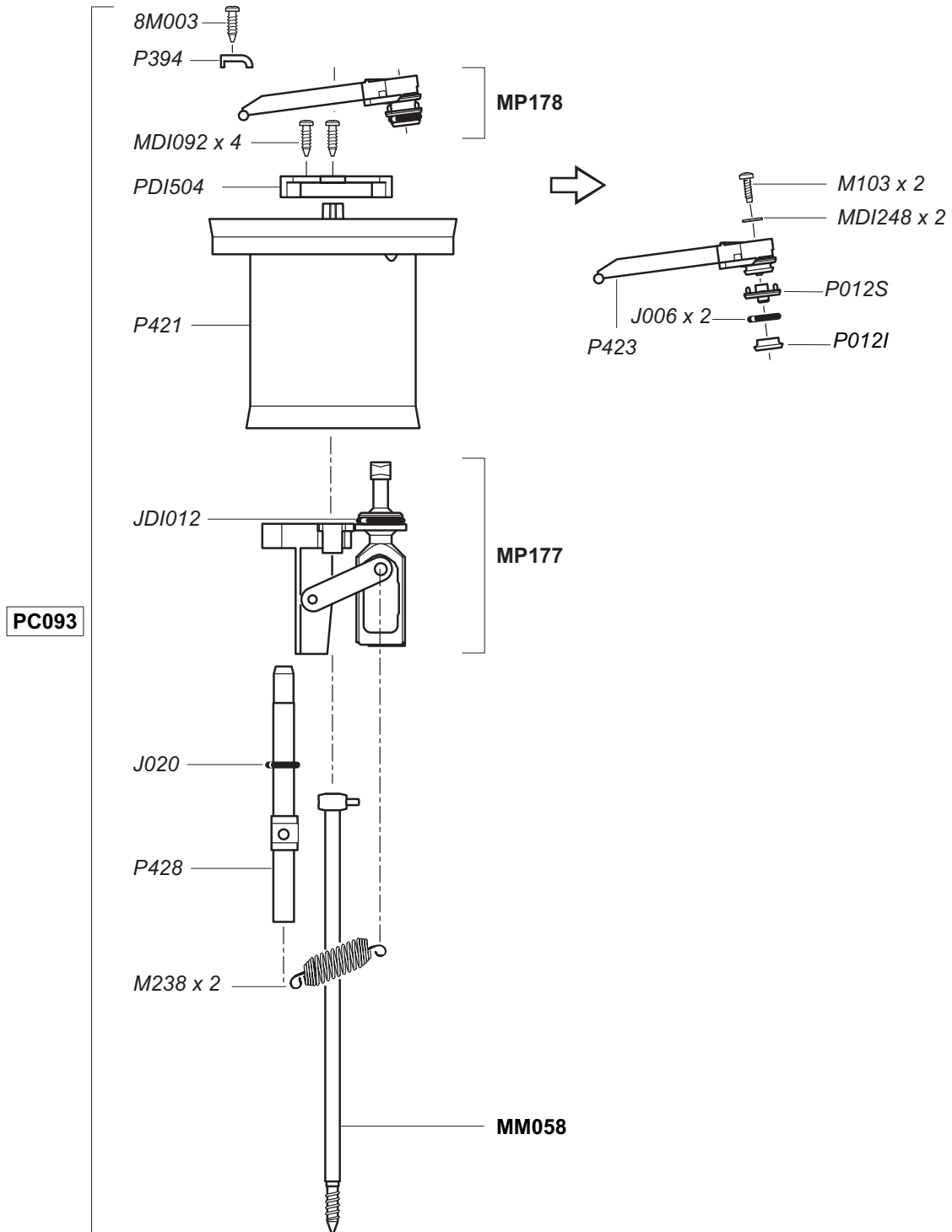

D25RE10

11/03

8.8 GPM - 1:33 - 1:10
4.3 - 57 psi

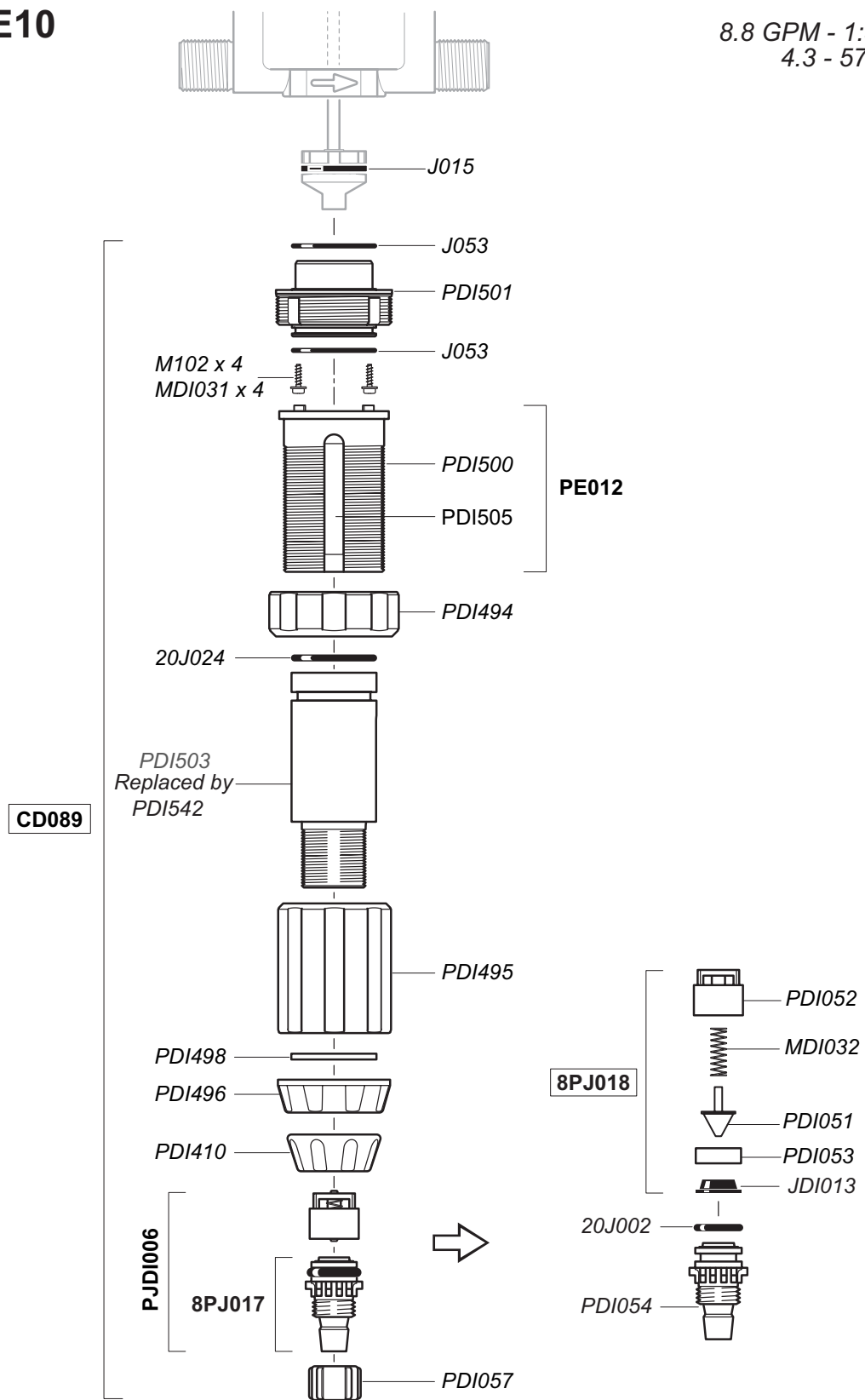

D25RE10

11/03

8.8 GPM - 1:33 - 1:10
4.3 - 57 psi

