



**DOSATRON®**

WATER POWERED DOSING TECHNOLOGY

---

# SCHEMATICS

## Dosatron Liquid Dispenser **Model # DI1500 – 11 GPM**

1:1500 – 1:500

4.3 – 85 PSI

$\frac{3}{4}$ " NPT Connection

### **Suggested Installation:**

200 mesh/80 micron water filter prior to unit

One-way check valve downstream from unit for water hammer protection

### **Suggested Maintenance Interval:**

Replace injection seals every 12 months

Replace Maintenance Kit components every 3 to 4 years

(Kit references available on Page 1)

---

### **DOSATRON SALES & SERVICE - NORTH & CENTRAL AMERICA**

Dosatron International, Inc.

Phone: 727-443-5404 Service: (800) 523-8499

Fax: 727-447-0591

[www.dosatronUSA.com](http://www.dosatronUSA.com)

**DI1500**  
11/03

11 GPM - 1:1500 - 1:500  
4.3 - 85 psi

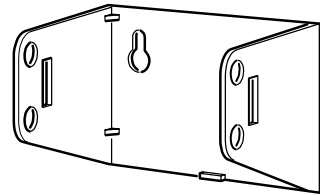
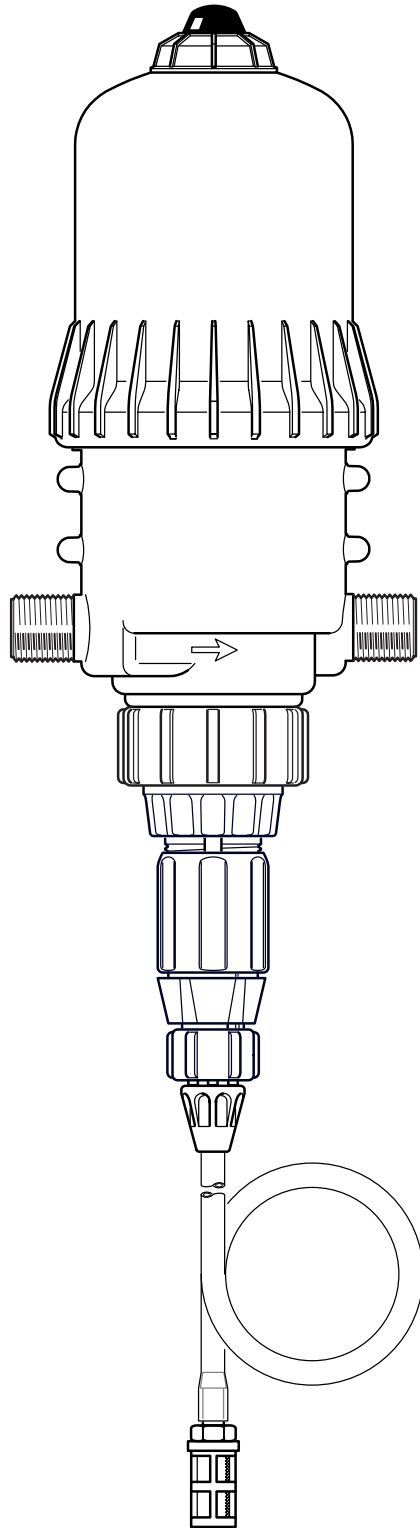

MKDI1500 Maintenance Kit

EDDI018 - Injection Seal Kit

**DI1500**  
11/03

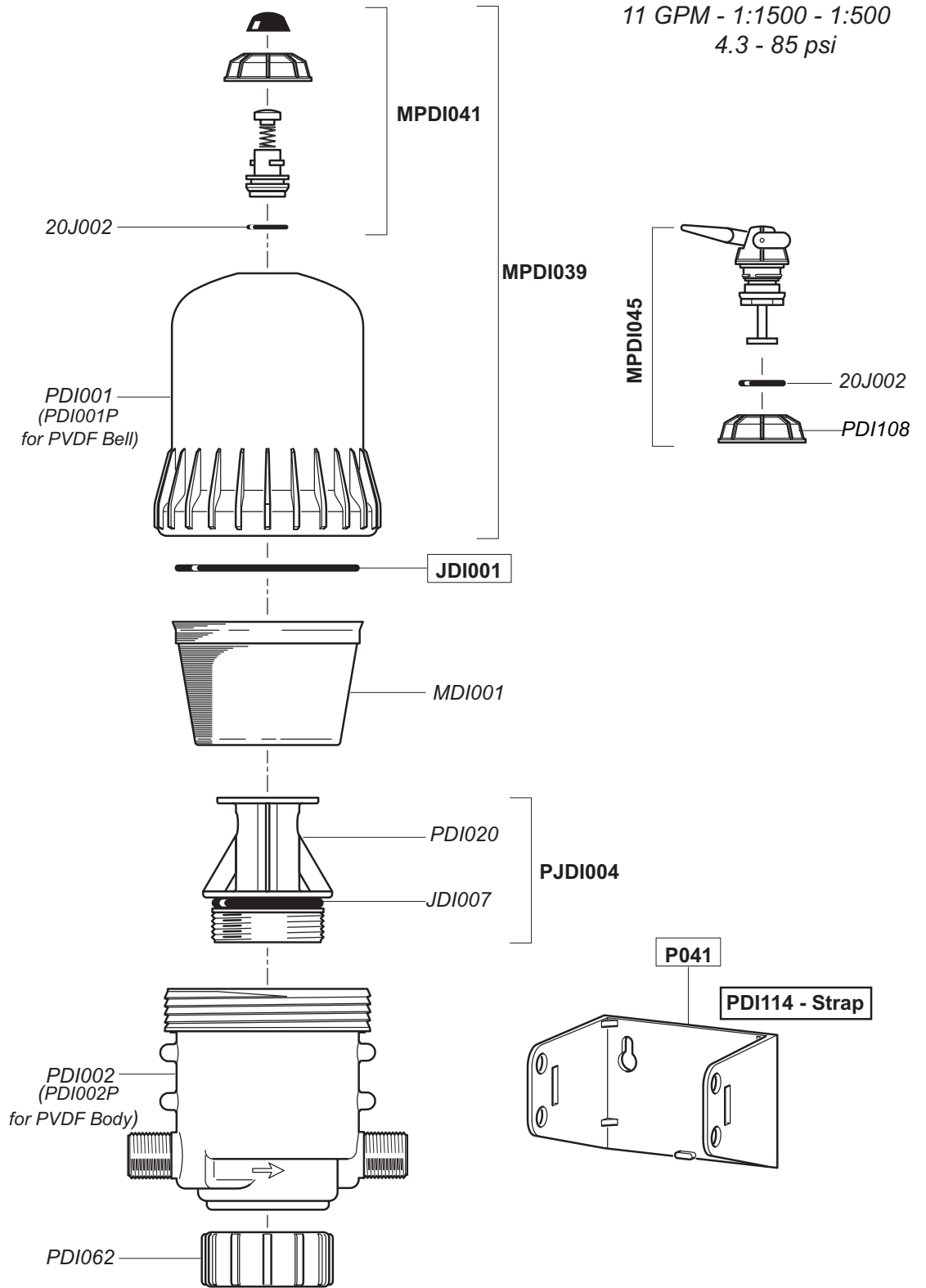

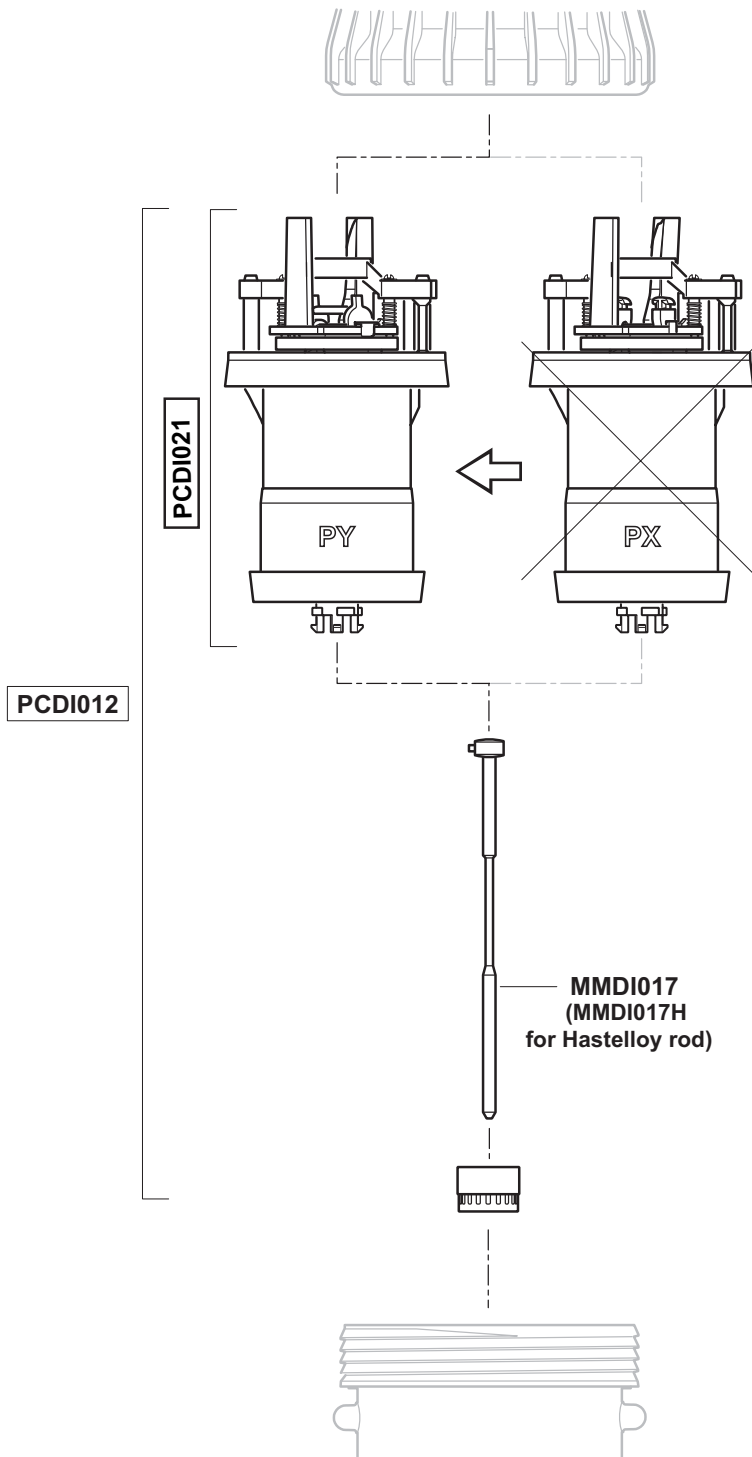



**DI1500**  
11/03

11 GPM - 1:1500 - 1:500  
4.3 - 85 psi

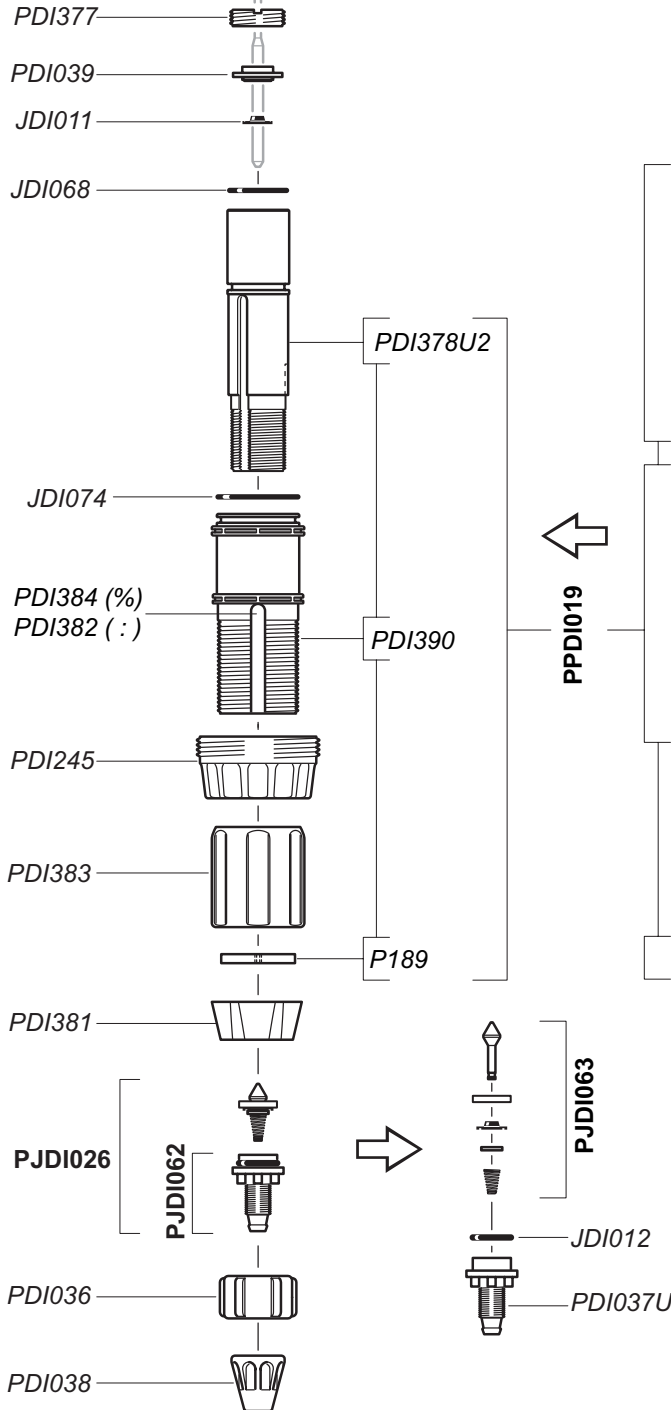
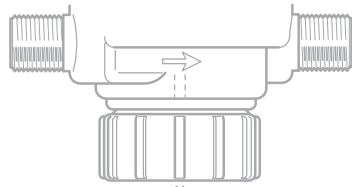

**New Style**  
CDDI048  
(Serial Number > 02321052)

**Old Style**  
(Serial Number < 02321052)

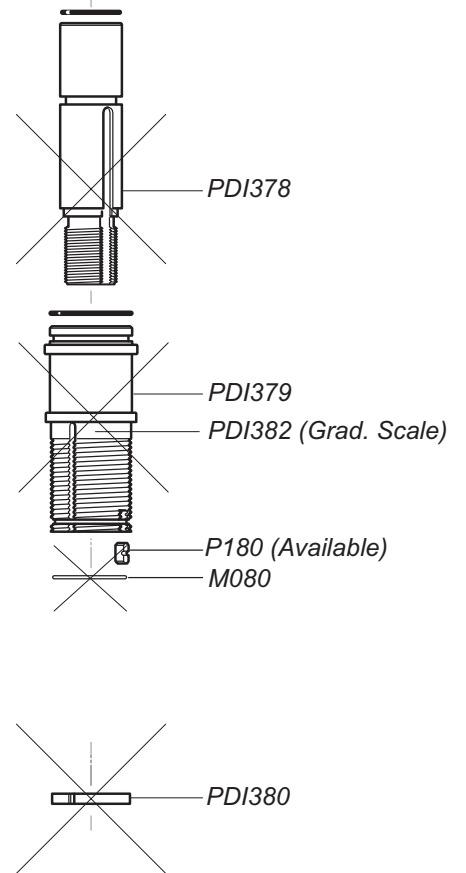

**DI1500**  
11/03

11 GPM - 1:1500 - 1:500  
4.3 - 85 psi

