

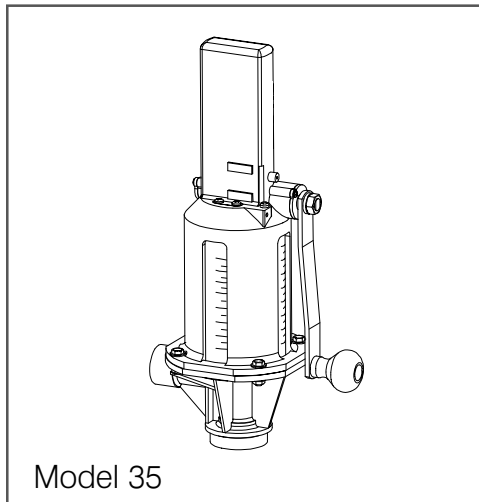

SERIES 35 VOLUMETRIC HAND PUMPS

For Models 35, 35C, 35L, 35CL



Model 35

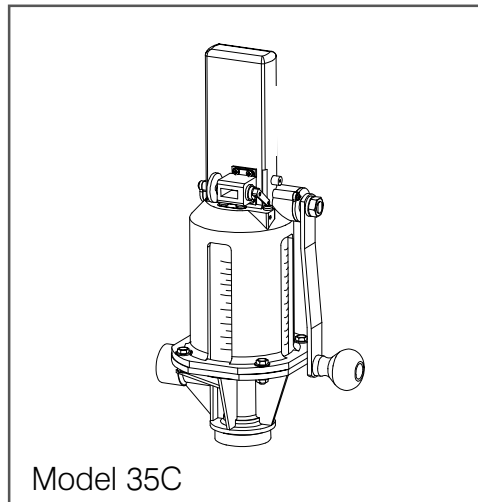

Model 35C

OUTSTANDING FEATURES

- Visible volumetric pumping chamber
- Accurately dispense one quart or one liter per full stroke
- Adaptable for barrels, storage tanks and drums
- Self-priming
- Telescopic suction pipe



TUTHILL CORPORATION

Sotera Systems

8825 Aviation Drive
Fort Wayne, Indiana USA 46809
Tel 219 747-9060 Fax 219 747-3934

Dear Sotera Customer,

Thank you for buying a Sotera product. Sotera Systems represents a new age in chemical handling products. This service guide contains valuable information about your new equipment and its operating and service requirements. Please take a few minutes to review this material carefully.

Sotera Systems' mission is to provide chemical handling products for ag-chem users that provide the most accurate, safe, convenient and economical way to transfer chemicals.

If, for any reason, any of the products do not meet your performance expectations we want to hear from you. Your comments and suggestions are requested and appreciated. Thank you again for buying a Sotera Systems product. We look forward to serving you in the future.

Sincerely,

Ron C. Bulloch
Vice President, Sales

SAFETY INSTRUCTIONS

To ensure safe and efficient operation, it is essential to read and follow each of the following warnings and precautions.

1. Agricultural herbicides flowing through the pump may be harmful to your health. Use and disposal of these products is controlled by federal, state or local laws and procedures.
2. Conform to fluid manufacturer's recommended handling procedures when using product and when cleaning pump.
3. Use Teflon tape or thread sealant on all threaded joints to avoid leakage of fluid. The 2" threaded port on pump inlet uses gasket F1312 and does not require a sealant.
4. Leave plunger all the way down when pump is not in use. Store pump out of direct sunlight.

GENERAL DESCRIPTION

The Sotera Systems Series 35 volumetric hand pump is manufactured from top quality, durable polypropylene and pumps one quart or one liter with every full plunger stroke. The visible pumping chamber allows smaller quantities to be accurately dispensed in ounces or milliliters.

TECHNICAL INFORMATION

Design Features

- Self-priming to 6 feet
- 1" NPT inlet and outlet
- 2" NPS bung mounting threads on inlet
- Telescopic suction pipe for drums up to 38"
- Adaptable for barrels, storage tanks and drums
- Accurate to better than 1% (1/3 oz. or 10 ml. per full stroke)

- Pump can vent the tank being pumped from or be sealed to the tank using the F1312 Bung Gasket.
- Hose kit with anti-drip spout (F1385)
- Maximum operating ambient temperature: 120°F

OPTIONS

- Quart or liter graduations
- Buttress adapter (F0615)
- Fill-Guard one way tank fittings
- Counter

Fluid Compatibility

If in doubt about compatibility of a specific fluid, contact supplier of fluid to check for any adverse reactions to the following wetted materials.

Polypropylene Body	Stainless Steel Valve Springs
Fluorocarbon Seals	Barex® Measuring Chamber

		DANGER
	<p>Not for use with fluids that have a flash point below 100°F (37.8°C, ie: gasoline, alcohol). Refer to NFPA 325M (Fire Hazard Properties of Flammable Liquids, Gases, and Volatile Solids) for flash points of common liquids. Static electricity buildup and discharge could result in arc and explosion.</p>	

Known Compatible Fluids

2 Plus 2®	Bicep®
DuPont Assure II®	†Dividend®
Fallow Master®	†Maxim®
FMC Furadan 4F®	†Apron®
Harness Xtra®	Nufos®
Roundup®	Touchdown®
Treflan®	Warrior®
Antifreeze (Ethylene Glycol)	Hydraulic Oil
Atrazine	Coolant Oil
Diesel	Methyl Parathion
Motor Oil	Transmission Fluid
Water	Zinc Chloride

†Requires F1462 self lubricating piston O-ring

Known Incompatible Fluids

Assert® Herbicide	Goal 2XL®
Acetone	Chlorine
Gasoline	Hydrochloric Acid 30%
MEK	Hydrofluoric Acid 25%
Methylene Chloride	Hydrogen Peroxide 30%*
Methanol	Nitric Acid
Potassium Hydroxide	Paint Remover
Sodium Hydroxide (50%)	Sulfuric Acid
Toluene	

Before using with acids or aggressive chemicals, check compatibility or consult the manufacturer.

INSTALLATION

Use appropriate chemical resistant pipe compound on all threaded joints.

1. Screw suction pipe into pump body and tighten firmly using a wrench. Extend telescoping tube to the approximate length of the tank.
2. Slide suction pipe and pump into tank or barrel.
3. Screw pump into tank or barrel.

TANK VENTING

In most cases, it is desirable to vent the tank being pumped from to prevent the container from collapsing. In some cases, however, special vents are required that do not allow fluid to escape should the tank tip over.

The Model 35 pump is self venting when screwed into a typical barrel when the F1312 bung gasket is **not** used. If venting is not sufficient (i.e., the tank begins to collapse) an additional vent hole can be drilled as shown.

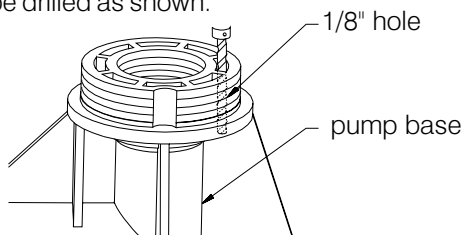

Use the F1312 bung gasket when the pump must be sealed to the tank. If using a Fill-Guard fitting, the F1312 gasket will seal the pump to the Fill-Guard.

QUICK DISCONNECT COUPLERS

The 35 pump is compatible for use with the following quick-disconnect couplers on drums or tanks:

- MICROMATIC® "Macro Valve" used with Stainless Steel drums.
- Scienco® products "Clean Lock"
- Other couplers that are rugged enough to couple a handpump without leaking

NOTE:

When using the Series 35 volumetric hand pump with the MicroMatic Drum Valve coupler, the pump needs to be held stable to prevent the drum valve coupler from allowing air to leak in. Firmly grasp the top of the pump with one hand while rotating the pump handle to prevent the pump from rocking on coupler.

USE

1. **Prime Pump:** Pump must be primed and purged of air to be accurate. If using a hose, prime the hose as well. The anti-drip spout option will keep the hose primed for best results. (See diagram and complete instructions on page 4.)
2. Grasp the top of the pump with one hand while rotating the crank with the other. Turn the crank clockwise until it stops to get a full quart or liter. Turn the crank counter clockwise to discharge fluid.

3. Measure from the bottom of the plunger (actual fluid level), when dispensing less than a full stroke.
4. Counter, if present, is activated only if a full stroke is made.
5. Leave plunger all the way down when not in use.

SERVICE

(Refer to exploded view)

1. Flush pump regularly when pumping corrosive fluids or fluid that will harden.
2. To lubricate the pinion (F1302) and rack (F1295) remove two screws (F1396) from the handle side of pump and pull out the pinion and handle assembly. Apply a liberal coat of thick grease to the pinion. Re-install pinion and tighten screws to snug. **Do Not** over tighten screws.
3. To lubricate or replace plunger O-ring, the base assembly (F0937) must be removed from the pump to access the plunger. Turn crank until plunger just sticks out of the tube. (Note: To completely remove the piston and rack, you must first remove the pinion and handle assembly. See #2 above.) Install a new O-ring if needed, being sure it is not twisted when installed. Liberally apply grease to the plunger O-ring. Carefully reinstall the plunger by pulling it in with the crank.
4. To position the handle (F1299) so it is pointing down when plunger is at the bottom of the stroke, remove the pinion and handle assembly as described in #2 above.
5. To replace measuring tube, remove base (F0937) and move plunger to the top of its stroke. Pierce the tube with a long screwdriver or drill bit just below the plunger. With a screwdriver through both sides of the tube, crank handle so that the plunger pushes the tube out. Stop cranking before screwdriver hits bottom of window and remove screwdriver. Remove tube and plunger. Note the tube stop on the inside of the shroud. Insert new tube, lining up graduation marks with windows on shroud. Install plunger and reassemble pump.
6. Inlet and outlet check valves require special tools to install; thus, they are only available in the base assembly. (F0937)

MAINTENANCE

Flushing

To flush the pump, pump a gallon or two of clean water through the pump and hose, then pump air through the pump to eliminate most of the water. Flush water should be disposed of properly.

Storage

Pump should be flushed, purged of liquid, and stored out of direct sunlight. Fluid should not be allowed to freeze in pump.

DIMENSIONS & RISER ADAPTER

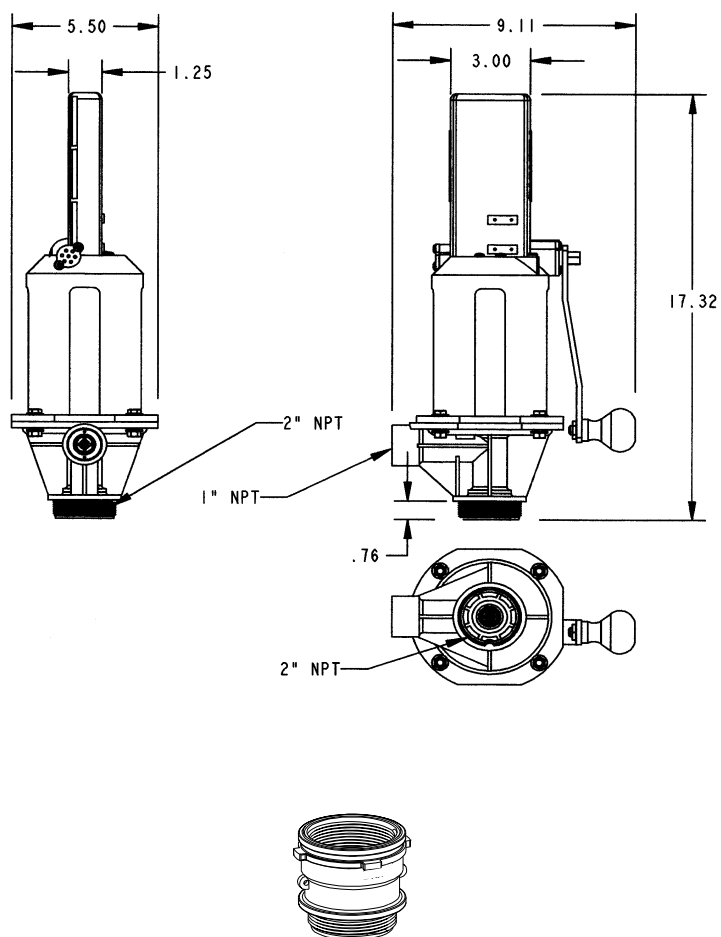

F0151 optional 2" riser for Bonar 55 L (14.5 gal.) rectangular keg, or other tank that has tall sides that prevent the pump from being threaded in.

F1385 HOSE KIT

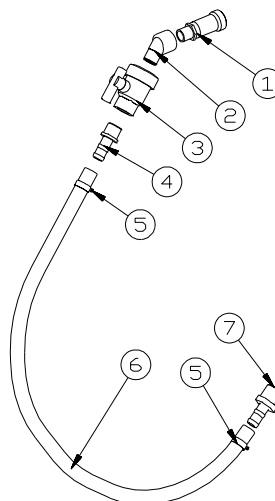

ITM. NO.	PART NO.	DESCRIPTION	QTY.
1	F1392	Anti-Drip Spout	1
2	F1387	45° Elbow	1
3	F3423	¾" Ball Valve	1
4	F0713	¾" Hose Barb	1
5	F3498	Hose Clamp	2
6	F0825	¾" ID EVA Hose	10 ft.
7	F1386	1" X ¾" Hose Barb	1
	F9121	Teflon Tape	1

Hose kit capacity

32 oz. (946ml) total fluid contained in F1385 10 ft. hose kit

- ¾" I.D. hose holds 3oz. (90ml) of liquid per foot of hose.
- ¾" ball valve (F3423) and Anti-drip nozzle holds 2oz. (60ml) of fluid.

Barex® is a registered trademark of BP Chemical. Treflan® is a registered trademark of Dow AgroSciences. Assure II® is a registered trademark of DuPont. Furadan 4F® is a registered trademark of FMC Corporation. Bicep®, Dividend®, Maxim®, & Apron® are registered trademarks of Novartis Corporation. Assert® is a registered trademark of American Cyanamid Company. Follow Master®, Harness Xtra®, & Roundup® are registered trademarks of Monsanto Corporation. Touchdown® & Warrior® are registered trademarks of Zeneca. 2 Plus 2® is a registered trademark of Isk Biosciences. Nufos® is a registered trademark of Cheminova. Goal 2XL® is a registered trademark of Rohm and Haas. Micromatic® is a registered trademark of Micromatic USA, Inc. Scienco® is a registered trademark of Ingersoll-Dresser Pump Company.

To Prime The Pump And Hose Kit:

The following simple procedure for priming the Series 35 when used in conjunction with the F1385 hose kit will help you maximize volumetric accuracy.

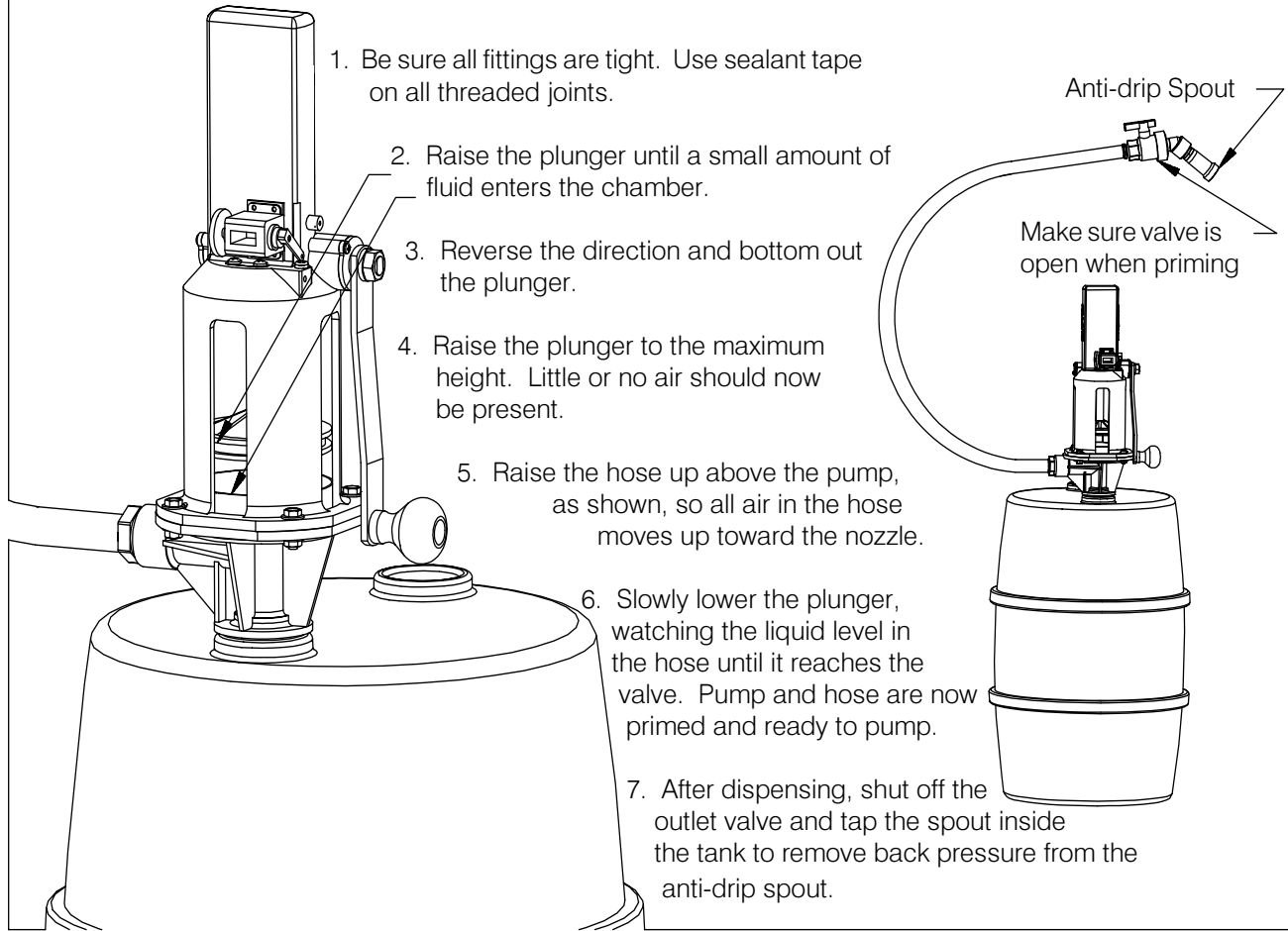

TROUBLESHOOTING GUIDE

PROBLEM	POSSIBLE CAUSE	SOLUTION
Pump will not prime	<ul style="list-style-type: none"> • Suction line problem • Check valve problem • Plunger O-ring damaged 	<ul style="list-style-type: none"> • Check for leaks in suction line. • Inspect inlet & outlet valves. • Replace O-ring.
Air in pump chamber	<ul style="list-style-type: none"> • Suction line problem line. 	<ul style="list-style-type: none"> • Check for leaks in suction
Pump fluid leakage above plunger	<ul style="list-style-type: none"> • Worn plunger seal • Worn /damaged tube 	<ul style="list-style-type: none"> • Replace plunger O-ring. • Replace Tube

MACRO VALVE Installation Instructions

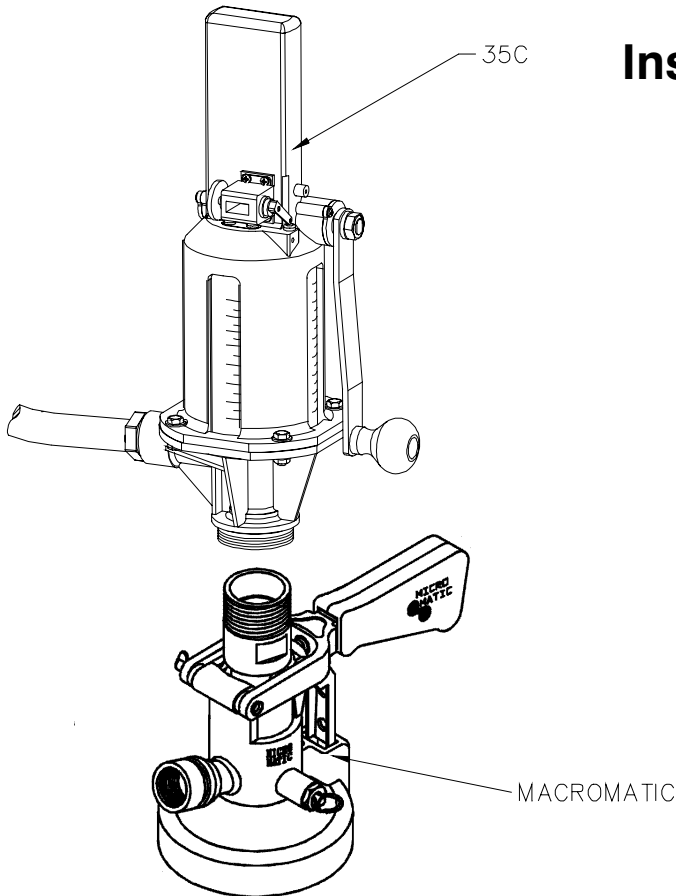

1. Apply thread sealant or Teflon tape to male threads of Macro Valve.
2. Thread Macro Valve into inlet threads of 35 pump. Tighten until two threads are showing.
3. Attach Macro Valve to container, following instructions furnished by Micro-Matic.

MICRO-MATIC DRUM VALVE Installation Instructions

1. Apply thread sealant or Teflon tape to both ends of 1" stainless steel nipple (F1394). Be sure to cover the full length of threads with sealant.
2. Thread 1" nipple into female threads on drum valve. Tighten well.
3. Thread other end of 1" nipple into inlet threads of 35 pump. Tighten until only two threads are showing below pump inlet.
4. Attach drum valve to container, following instructions furnished by Micro-Matic.

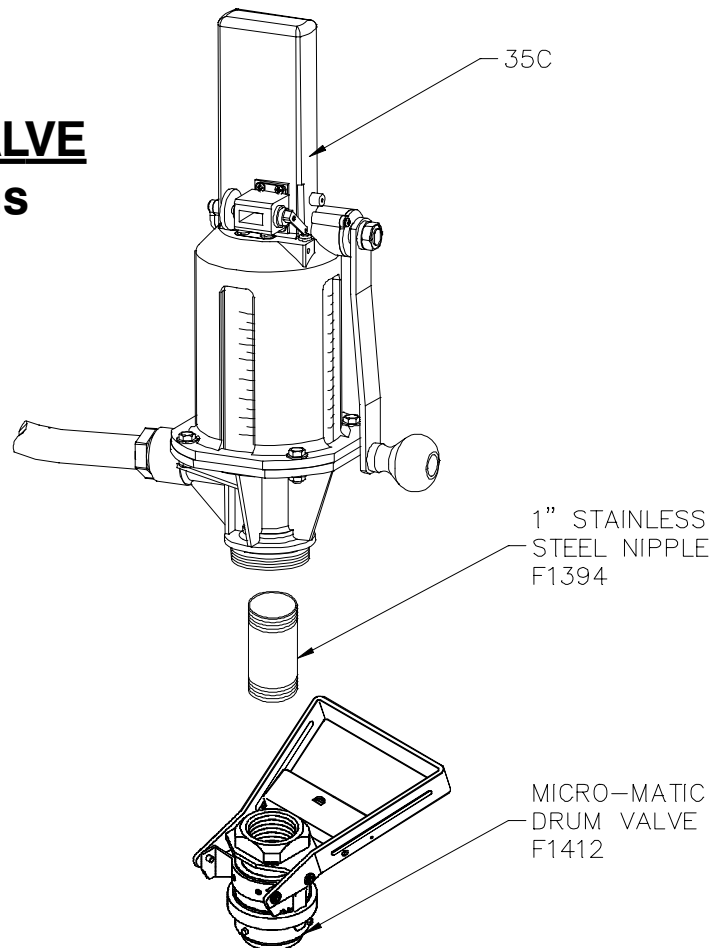

**WELCOME TO A NEW AGE
IN CHEMICAL HANDLING PRODUCTS.**

With the creation of Sotera Systems, Tuthill Corporation has ushered in a new age in chemical handling products for the ag-chem dealer and agricultural user. After more than 35 years of product research and development in fuel and chemical handling equipment, Tuthill Corporation has created Sotera Systems to focus solely on the needs of the ag-chem industry.

You'll recognize the familiar Tuthill traits in every Sotera Systems product, like the uncompromising quality, workmanship and dependability you've always relied on. But Sotera Systems is something more, something unique. It's designed, engineered, tested and serviced by ag-chem people. People who understand the needs of the ag-chem world, the changes that are taking place, and the chemical handling solutions it will take to meet those needs.

**A SPECIAL MARKETPLACE.
A SPECIAL COMPANY.**

The ag-chem market is a dynamic, ever-changing world, which means it is not an industry you can know at a glance. You have to be entrenched. That's why Sotera Systems is out in the fields talking to farmers, dealers and other ag-chem users, and listening to what they have to say.

And they say plenty – everything from concerns about safety, accuracy and governmental policies to convenience, cost and dependability. By being in the fields, Sotera Systems gains tremendous insight into the needs of ag-chem dealers, manufacturers and end users. And uses this information to create products that make sense for their market. It takes a dedicated company to grasp every detail and translate it into ag-chem products that perform. It takes a company like Sotera Systems.

AG-CHEM PRODUCTS. AG-CHEM SUPPORT.

Sotera Systems is not just another product line, it is our only line. Day in and day out, our attention and commitment is to the ag-chem market. And this commitment goes beyond the manufacturing of quality chemical-handling systems; it includes world-wide product support and technical expertise even when you're in the field. Our distributors and dealers are knowledgeable ag-chem professionals who offer years of experience and the latest in chemical-handling advice. Our mission is to lead the way in finding innovative ways to transfer chemicals safely, accurately, conveniently and economically. In partnership with the ag-chem market, Sotera Systems will champion a new age of chemical handling.

PRODUCT WARRANTY

Sotera Systems of Tuthill Corporation ("Manufacturer") warrants to each buyer of its products ("the Buyer") for a period of 12 months from date of invoice or sales receipt but in no event more than 18 months from date of manufacture that goods of its manufacture ("Goods") will be free from defects of material and workmanship. Manufacturer's sole obligation under the foregoing warranties will be limited to either, at Manufacturers' option, replacing or repairing defective Goods (subject to limitations hereinafter provided) or refunding the purchase price for such Goods theretofore paid by the Buyer, and Buyer's exclusive remedy for breach of any such warranties will be enforcement of such obligations of Manufacturer. If Manufacturer so requests the return of the Goods, the Goods will be redelivered to Manufacturer in accordance with Manufacturer's instructions F.O.B. Factory. The remedies contained herein shall constitute the sole recourse of the Buyer against Manufacturer for breach of warranty. **IN NO EVENT SHALL MANUFACTURER BE LIABLE FOR CONSEQUENTIAL DAMAGES, NOR SHALL MANUFACTURER'S**

LIABILITY ON ANY CLAIM FOR DAMAGES ARISING OUT OF THE MANUFACTURE, SALE, DELIVERY OR USE OF THE GOODS EXCEED THE PURCHASE PRICE OF THE GOODS. The foregoing warranties will not extend to Goods subjected to misuse, neglect, accident or improper installation or maintenance, or which have been altered or repaired by anyone other than Manufacturer or its authorized representative. **THE FOREGOING WARRANTIES ARE EXCLUSIVE AND IN LIEU OF ALL OTHER WARRANTIES OF MERCHANTABILITY, FITNESS FOR PURPOSE OF ANY OTHER TYPE, WHETHER EXPRESS OR IMPLIED.** No person may vary the foregoing warranties and remedies except in writing signed by a duly authorized officer of Manufacturer. Warranties or remedies that differ from the foregoing shall not otherwise be binding on Manufacturer. The Buyer's acceptance of delivery of the Goods constitutes acceptance of the foregoing warranties and remedies, and all conditions and limitations thereof.

