

# 66 Series, TSP

High Pressure Triplex Plunger Pump

## FEATURES

- Compact, High Pressure
- Oversized roller bearings
- Fully anodized crankcase
- Innovative new seal design extends seal life
- New plunger design improves “thermal shock” resistance
- New valve cap design improves hydrostatic performance
- Also available in “L” left-handed versions



## SPECIFICATIONS

Pump Model	TSP1619	TSP1619 Alternate Spec	TSP1621	TSP1819	TSP1821
Maximum GPM	3.6	4.3	4.3	5.0	5.5
Maximum PSI	7250	5800	6525	5100	
Horsepower	17.8 EBHP	17.8 EBHP	17.1 EBHP	17.1 EBHP	18.8 EBHP
Maximum RPM	1450	1750	1450		
Inlet PSI Maximum (Minimum)	125 PSI (2.6 in Hg)				
Plunger Bore (mm)	.629 (16)	.629 (16)	.629 (16)	.709 (18)	.709 (18)
Plunger Stroke (mm)	.748 (19)	.748 (19)	.826 (21)	.748 (19)	.826 (21)
Oil Capacity	31.0 oz				
Maximum Fluid Temperature	165°F				
Inlet Port Thread	1/2" BSP-F				
Discharge Port Thread	3/8" BSP-F				
Shaft Diameter (mm)	.945 (24)				
Weight lb(kg)	40.7 (18.5)				
Dimensions	13.8 x 9.8 x 7.7 in				

## DIMENSIONS

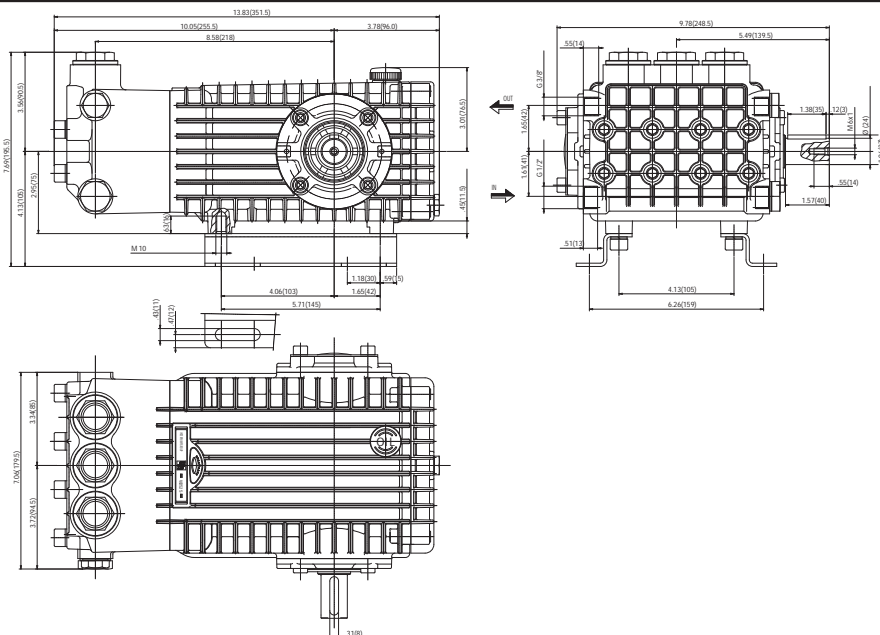

# 66 Series, TSP

**GENERAL PUMP** *A member of the Interpump Group*

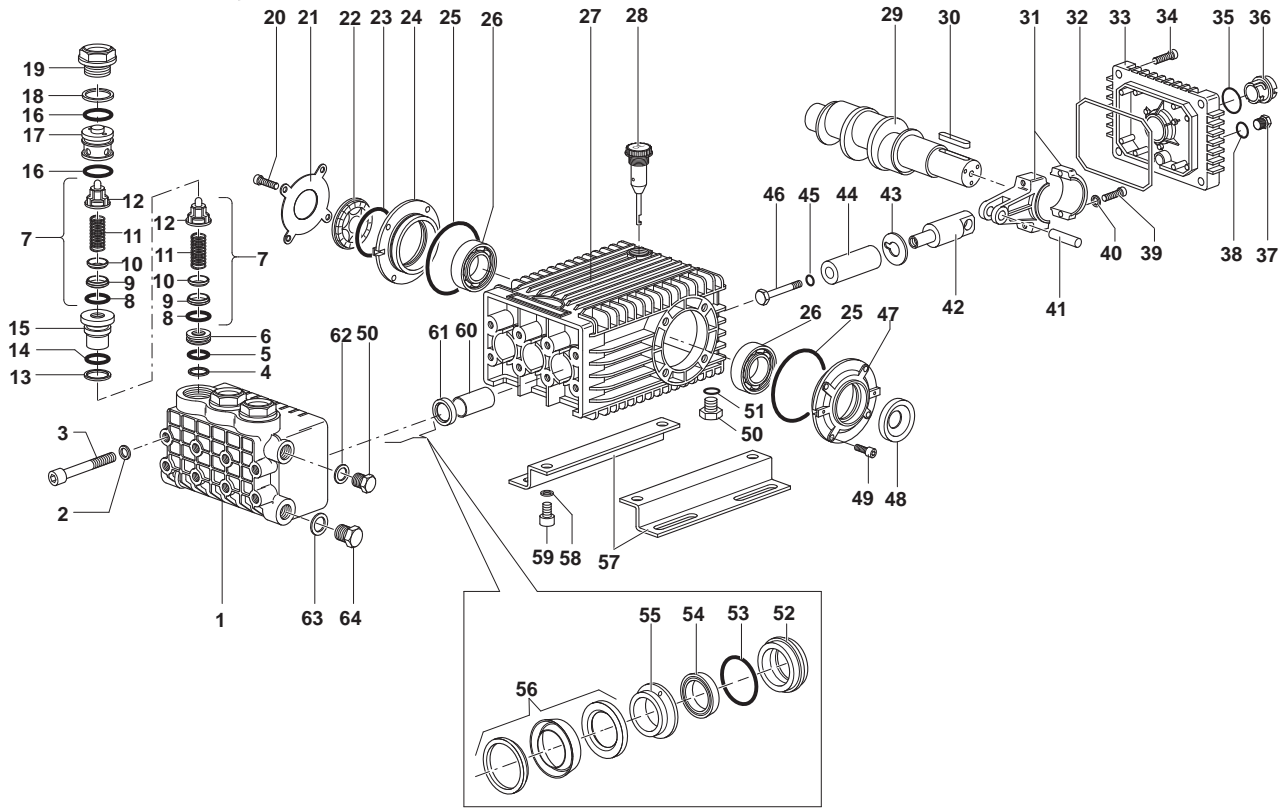

## REPAIR KITS

ITEM	PART NO.	DESCRIPTION	QTY.	ITEM	PART NO.	DESCRIPTION	QTY.	ITEM	PART NO.	DESCRIPTION	QTY.
1.	66121041	Manifold 16mm	1	24.	66150122	Side Cover	2	46.	66219566	Plunger Bolt	3
	66121141	Manifold 18mm	1	25.	701147	O-ring 67.95 x 2.62	2	47.	66150022	Side Cover, PTO	1
2.	96710400	Washer M10	8	26.	91838000	Bearing	1	48.	90164800	Seal, Shaft 30 x 55 x 7	1
3.	99382000	Headbolt M10 x 120	8	27.	66010022	Crankcase	1	49.	99303900	Screw M8 x 16	4
4.	90511800	Anti-ext ring	3	28.	98210600	Dipstick, vented	1	50.	98210000	Plug 3/8 x 13	2
5.	90359600	O-ring 18.77 x 1.78	3	29.	66020435	Crankshaft TSP1621	1	51.	90383300	O-ring 13.95 x 2.62	1
6.	66210270	Spacer M12	3		66020035	Crankshaft TSP1819		52.	66080270	Seal Retainer 16mm	3
7.	36712101	Valve Assy., Complete	6	30.	91489200	Key	1		66080370	Seal Retainer 18mm	
8.	90384100	O-ring 17.13 x 2.62	6	31.	66030001	Connecting Rod	3	53.	90361600	O-ring 34.65 x 1.78	3
9.	36200366	Valve Seat	6	32.	90392200	O-ring 133.02 x 2.62	1	54.	90263100	LP Seal 16mm	3
10.	36203266	Valve Poppet	6	33.	66160000	Cover, Crankcase	1		90265200	LP Seal 18mm	
11.	94737600	Valve Spring	6	34.	99188400	Screw M6 x 20	4	55.	66216270	Intermediate Ring 16mm	3
12.	36202551	Valve Guide	6	35.	90405100	O-ring 26.58 x 3.53	1		66216370	Intermediate Ring 18mm	
13.	90511500	Anti-ext ring	3	36.	63210051	Sightglass, Bayonet style	1	56.	90263400	HP Seal 16mm	3
14.	90384300	O-ring 17.86 x 2.62	3	37.	98204100	Plug, G1/4" x 9	1		90265500	HP Seal 18mm	
15.	66210166	Bushing	3	38.	90358500	O-ring 10.82 x 1.78	1	57.	47200074	Pump Rail	2
16.	90385700	O-ring 23.81 x 2.62	6	39.	99309900	Screw M8 x 35	6	58.	96710600	Washer M10	4
17.	66210070	Plug 19mm	3	40.	96701400	Locking Washer M8	6	59.	99364400	Screw M10 x 18	4
18.	90516500	Anti-ext ring	3	41.	97740500	Wrist Pin	3	60.	90912600	Guide Bushing	3
19.	66130141	Valve Cap	3	42.	66050064	Piston Guide	3	61.	90162500	Seal, Pl. Rod 22 x 32 x 5.5	3
20.	99306900	Screw M8 x 25	4	43.	96710100	Flinger Washer	3	62.	96738000	Gasket, Aluminum 3/8"	1
21.	66150274	Cover	1	44.	66040209	Plunger 16 x 54	3	63.	96751400	Gasket, Aluminum 1/2"	1
22.	44211801	Spacer, Sightglass	1		66040309	Plunger 18 x 54		64.	98217600	Plug, G1/2" x 10	1
23.	90409700	O-ring 55.56 x 3.53	1	45.	701013	O-ring 10.82 x 1.78	3				

## REPAIR KITS

Kit	K02	K03	K150	K174	K175	K180	K176
<b>Bore</b>	All	All	All	16mm		18mm	
<b>Items</b>	61	48	8,9,10,11,12 (7)	54,56	52,53,54, 55,56	54,56	52,53,54, 55,56
<b>Qty</b>	1	1	6	1	3	1	3

## TORQUE SPECS\*

Item	N-M	Ft-lbs
3	45	33.2
19	130	95.9
20	20	14.8
34	10	7.4
37	20	14.8
39	20	14.8
46**	20	14.8
49	20	14.8
50	40	29.5
59	40	29.5

\*Decrease torque by 20% if threads are lubricated.

\*\* Use Loc-tite 542

Ref 310046 Rev. F  
11-08

**GENERAL PUMP** 1174 Northland Drive • Mendota Heights, MN 55120

Phone: (651)686-2199 • Fax: (800)535-1745 • e-mail: sales@gpcompanies.com • www.generalpump.com

