

Please read and save this Repair Parts Manual. Read this manual and the General Operating Instructions carefully before attempting to assemble, install, operate or maintain the product described. Protect yourself and others by observing all safety information. The Safety Instructions are contained in the General Operating Instructions. Failure to comply with the safety instructions accompanying this product could result in personal injury and/or property damage! Retain instructions for future reference.

# **SHERTECH**® Bronze Pedestal Self-Priming Flexible Impeller Pumps

Refer to form L-4082 for General Operating and Safety Instructions.

## Description

Shertech bronze, pedestal, self-priming, positive displacement, flexible impeller pumps provide a nearly pulseless flow with no metal-to-metal contact. This pedestal pump drive series includes a 303 stainless steel drive shaft with heavy-duty ball bearing and carbon graphite bushing, providing for direct drive or pulley operation. Features include: bronze and/or brass pump body, cam and cover; standard Buna-N mechanical seal with carbon ceramic faces and Nitrile impeller.

Uses: Handle a wide range of industrial, marine, agricultural and commercial applications where non-abrasive fluids compatible with pump wet-end construction component materials are pumped. Pumps are suitable for the transfer of non-lubricating fluids, mild abrasives, fluids containing small particles in suspension, and a wide variety of viscous fluids such as petroleum-based oils, silicone greases, and hydraulic fluids. These units are ideal for water drainage transfer, barrel emptying, machine coolant recycling, and an assortment of related utility activities.

**NOTE:** Flexible impeller failure will occur immediately if pump is run dry, and this is not covered under warranty. Use caution to not touch the pump if you have dry run it, because it will be extremely hot.

- Flows up to 36.5 GPM at 3450 RPM.
- Maximum discharge pressure is 25 PSI (60 ft. of head).
- Max. RPM: 3450.
- Suction lift to 13.5 ft.
- Buna-N mechanical seal with carbon ceramic wear faces and 18-8 stainless steel components.
- Maximum viscosity up to 500 SSU and 25 PSI (60 ft. of head) at 1725 RPM or run at reduced speeds to handle a wide range of pump fluid viscosities (up to 2500 SSU) and specific gravity (up to 1.3). DO NOT pump oils or petroleum derivatives with optional neoprene impellers. (Maximum torque loads are found in the performance chart.)
- Pumps can operate bi-directionally (reversible).
- Temperature range with Nitrile impellers is 0°F - 180°F (optional neoprene impellers is 15°F - 130°F).
- Includes a 303 stainless steel drive shaft with heavy-duty ball bearing and carbon graphite bushing, providing for direct drive or pulley operation.

**BRONZE MODELS** – Excellent for water-based fluids. Features include: bronze and/or brass pump body, cam and cover; standard Buna-N mechanical seal with carbon ceramic faces and Nitrile impeller. Wet-end parts are constructed from bronze, brass, Nitrile, carbon, ceramic and stainless steel (18-8, 303 and/or other 300 series).

**REPAIR IMPELLERS AND OPTIONS** – Standard impellers are Nitrile, and they and the optional neoprene impeller can be located in the repair parts list pages of this manual.

**NOTE:** Bronze and 316 stainless steel flexible impeller pumps are also available as close-coupled models for custom installation. They are equipped with motors.



**WARNING:** Do not use to pump flammable or explosive fluids such as gasoline, fuel oil, kerosene, etc. Do not use in flammable and/or explosive atmospheres. When pumping hazardous or dangerous materials, use only in a room or area designated for that purpose. For your protection, always wear proper clothing, eye protection, etc. in case of any malfunction. For proper handling techniques and cautions, contact your chemical supplier, insurance company and local agencies (fire dept., etc.). Failure to comply with this warning could result in personal injury and/or property damage.

# SHERTECH® Bronze Pedestal Self-Priming Flexible Impeller Pumps

## Model Ordering Codes and Options

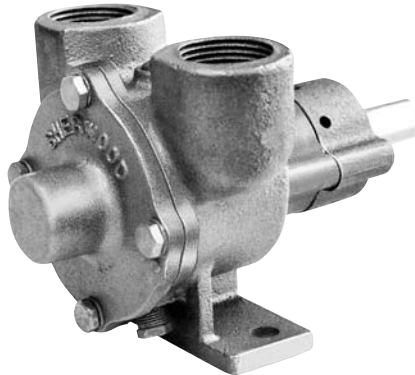

**Example Model: R50GN** (will require 1 HP ODP motor with >1.15 Service Factor\*)  
(motor not supplied with pedestal pump)

Model**	Impeller Size (Ports***)	Impeller Option
R: Bronze Flexible Impeller Pump	30G (1/2") 50G (3/4") 102 (1")	Blank: Neoprene  N: Nitrile

(1) R                  (2) 50G                  (3) N  

**NOTE:** Not all order code combinations (configurations) are standard models available from the manufacturer. Custom model configurations may require ordering standard components and/or optional parts that will need to be assembled by the customer.

Manufacturer reserves the right to change model order codes, standard models, specifications, and performance without notification.

Pedestal Pumps are not supplied with a motor.

Maximum motor speed is 3600 RPM.

R series pumps are all pedestal mounts for multi-speed configurations.

(\*) ODP motors have > 1.15 service factors. Due to service factor, it is recommended TEFC motors are oversized by one HP increment.

(\*\*) Has a Buna-N carbon ceramic mechanical seal.

(\*\*\*) Port size inlet and outlet (in inches).

## Models R30GN, R50GN and R102N

### Performance (with Water)

Model	Port Size*	HP**	Max. Input Torque in.-lbs.	RPM	Suction Lift***	GPM Pumping Water at 70° F @ Total Feet of Head						
						Free Flow	10	20	30	40	50	60 <sup>†</sup>
R30GN	1/2	1/3	11	1750	8.1	5.7	5.5	5.0	4.8	4.6	4.3	4.1
		1/2		3450	9.8	10.8	10.5	10.2	10.0	9.6	9.3	9.0
R50GN	3/4	3/4	21	1750	9.4	13.1	11.5	11.0	10.6	10.1	9.0	7.8
		1		3450	12.0	23.9	23.5	22.5	21.9	20.6	19.4	17.6
R102N	1	1	29	1750	10.2	20.2	19.6	18.8	18.0	17.0	16.0	14.7
		1½		3450	13.5	36.5	33.0	32.5	31.7	30.7	29.5	27.5

Test data taken with water at 70° F (to convert data to PSI, divide feet of head by 2.31).

Pump performance when pump is new. As pump wears, the performance will decrease.

(†) Extended operation beyond 60 feet of head will result in immediate impeller failure.

(\*) Female NPT inlet and outlet (in inches).

(\*\*) Suggested horsepower; pumps do not ship with motors.

(\*\*\*) Suction lift requires wetted impellers and seal chamber.

**NOTES:** Consult tables on HP adders and speed recommendations for high viscosity fluids. The pump relationship between volume (GPM), pressure (PSI), speed (RPM) and horsepower is shown on Performance Chart in Shertech Motor Manual form L-4082. When pumping a more viscous liquid, a slower speed, a larger pipe size pump, and possibly a larger motor should be selected.

Max. Viscosity = 500 SSU at 1725 RPM (at 1.0 specific gravity).

Max. Input Torque = see chart above.

Max. RPM = 3450.

Max. Specific Gravity = 1.0 at 25 PSI, up to 1.3 at lower PSI & viscosity.

Do not use Neoprene impellers with oil.

Manufacturer reserves the right to change performance without notification.

# **SHERTECH®** Bronze Pedestal Self-Priming Flexible Impeller Pumps

## Specifications

Model	Max. RPM	NPT Inlet & Outlet Port	Pump Shaft Size*	Drive Shaft End Bearings	PUMP CONSTRUCTION (Wet End)							Ship Wt. (lbs.)
					Impeller Material**	Body, Cam & Cover Castings	Keys & Clip	Shaft†	Wet End Shaft Bearings	Gasket	Seal***	
R30GN	3450	1/2"	1/2"	Nitrile	BZ & BR	300 Series SS	SS	CG	Ball	Vellumoid	Buna	4.2
R50GN	3450	3/4"	5/8"	Nitrile	BZ & BR	300 Series SS	SS	CG	Ball	Vellumoid	Buna	5.2
R102N	3450	1"	5/8"	Nitrile	BZ & BR	300 Series SS	SS	CG	Ball	Vellumoid	Buna	6.6

SS = Stainless Steel CG = Carbon Graphite BR = Brass BZ = Bronze

(†) 303 or 300 Stainless Steel Series

(\*) The shafts have drive slots with key for drive couplers or pulleys.

(\*\*) The impeller insert can be made of bronze, brass or 300 Series Stainless Steel.

(\*\*\*) Mechanical seal with carbon ceramic faces and 18-8 Series Stainless Steel components.

**NOTE:** Manufacturer reserves the right to change specifications without notification.

# Models R30GN, R50GN and R102N

## Dimensions

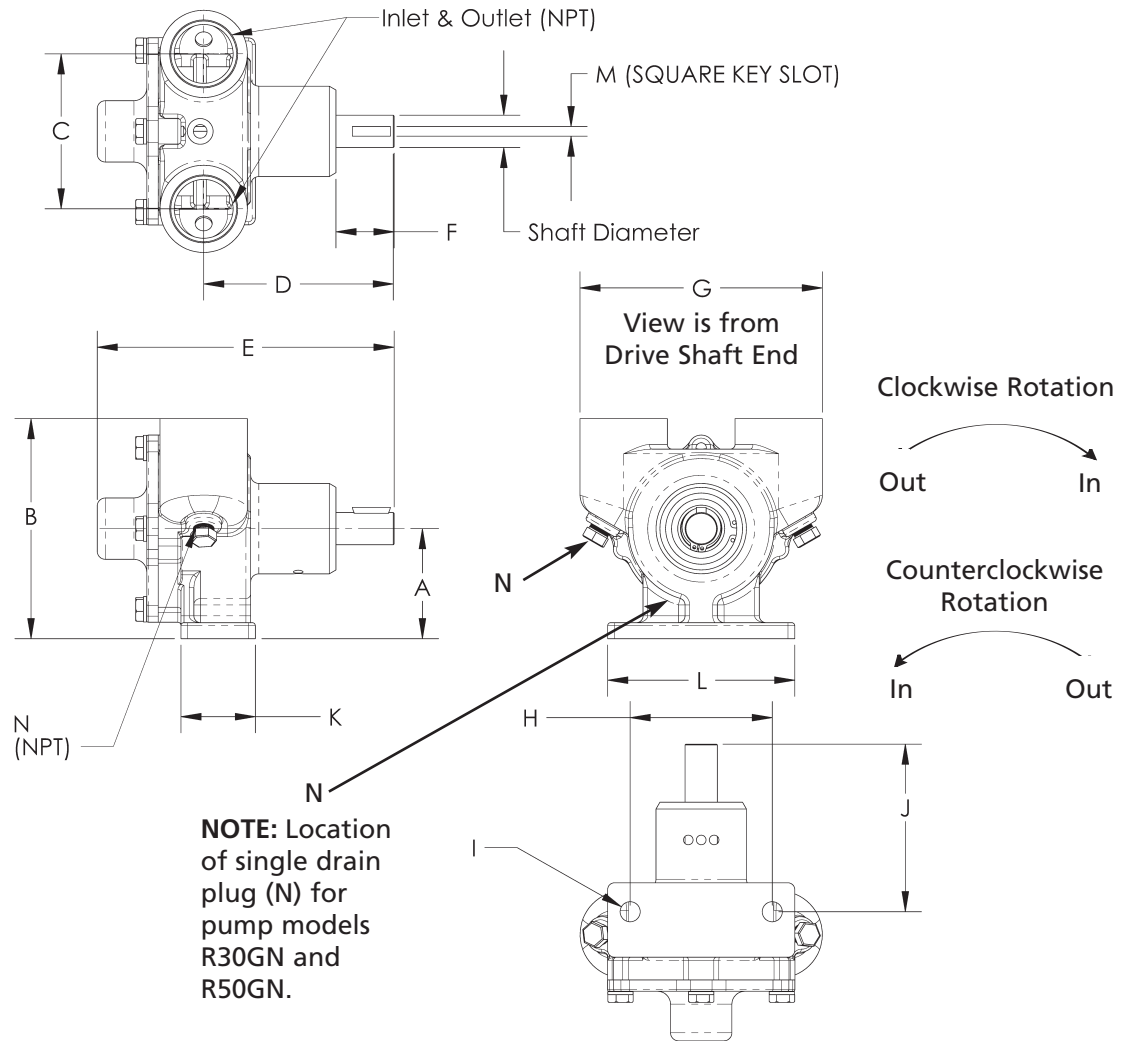

Figure 1

**NOTE:** Location of single drain plug (N) for pump models R30GN and R50GN.

Model	Inlet & Outlet Port*	Shaft Dia.**	Dimensions (in inches)													
			A	B	C	D	E	F	G	H	I	J	K	L	M**	N*
R30GN	1/2	1/2	1.63	3.10	2.26	3.19	5.63	1.84	3.38	2.13	.034	3.75	1.12	2.94	0.125	1/8
R50GN	3/4	1/2	2.13	3.75	2.50	4.08	5.93	1.51	3.86	2.25	0.41	3.37	1.25	3.00	0.18	1/8
R102N	1	5/8	2.13	4.26	3.00	3.68	5.69	1.12	4.69	2.75	0.39	3.24	1.44	3.62	0.18	1/8

(\* ) Standard NPT (female) pipe thread. Models R30GN and R50GN only have one drain plug (one dimension N).

(\*\* ) The shafts have drive slots with key for drive couplers or pulleys.

**NOTE:** All dimensions have a tolerance of (+ or -) 1/8".

Manufacturer reserves the right to change dimensions without notification.

# SHERTECH® Bronze Pedestal Self-Priming Flexible Impeller Pumps

## Impeller Identification Chart

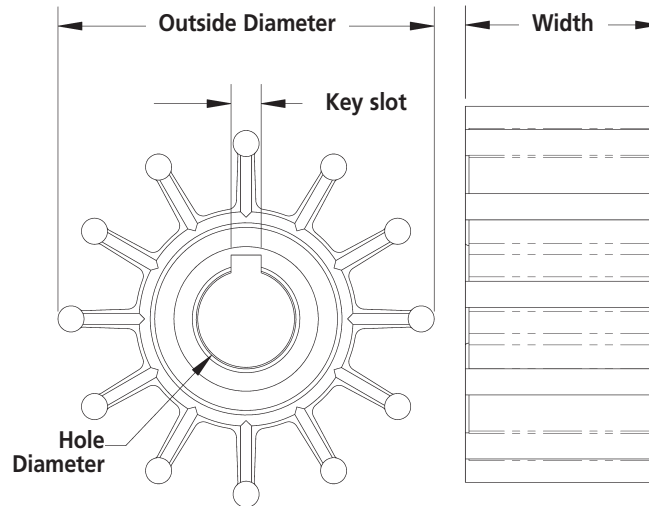

Impeller Part Number	Material	(Dimensions in inches)				Number of Blades
		Outside Dia.	Width	Hole Dia.	Key slot	
10077S	Neoprene	2.23	0.78	0.53	0.09	12
09959S	Neoprene	2.45	1.25	0.63	0.18	12
10615S	Neoprene	2.58	1.63	0.63	0.18	12
12336S	Nitrile*	2.23	0.78	0.53	0.09	12
21251S	Nitrile*	2.45	1.25	0.63	0.18	12
19317S	Nitrile*	2.58	1.63	0.63	0.18	12

Refer to Repair Parts list pages in this manual to match up impeller with pump model.

(\*) Nitrile is standard and is equivalent to Buna-N. Nitrile is suggested for pumping oil-based fluids, and Neoprene is suggested for pumping water-based fluids.

**NOTES:** Dry running will result in immediate failure of impeller and cause extreme pump temperature (do not handle pump when hot).

Impeller damage is not covered under warranty.

Manufacturer reserves the right to change dimensions without notification.

## Models R30GN, R50GN and R102N

**⚠ WARNING** *Check motor. It may be equipped with an automatic resetting thermal protector and may restart unexpectedly (see specifications chart). Protector tripping is an indication of motor overloading as a result of operating the pump at too high a pressure (over 25 PSI or 60 feet of head), too high of viscosity, too high of specific gravity, excessively high or low voltage, inadequate wiring, incorrect motor connections, too small a motor (sized incorrectly, not enough HP), or a defective motor or pump.*

*Do not handle pump with wet hands or when standing in water. Failure to follow the General Safety Information and all warnings could result in fatal electrical shock!*

### Installation

**IMPORTANT:** In any installations where property damage and/or personal injury can occur when the pump is not operating due to power outages, discharge line freezing, or any other reason, a back-up system(s) and/or warning system(s) should be used.

In order to safely use this product, familiarize yourself with this pump and also with the liquid (chemical, etc.) that is going to be pumped through the unit. This pump is not suitable for many liquids.

1. Locate the pump as close to the liquid source as possible, making the suction line as short and direct as possible.

### PIPING

#### SUCTION

2. Avoid excessive lengths or number of fittings and bends in the suction line.
3. Attach suction line to suction inlet (See Figure 1 for proper rotation).

**NOTE:** An optional vacuum switch (pump protector) is recommended to prevent pump dry run. It should be mounted on the suction side of the pump. Refer to installation/operation instructions provided with vacuum switch.

4. It is recommended that same size pipe as pump ports be used or, in cases requiring lengthy piping, the next larger size pipe be used.
5. If suction level is greater than what is indicated in the performance chart, attach a foot valve below liquid level at end of suction line to ensure positive priming. Also note: If fluid specific gravity is greater than 1.0 or viscosity greater than 500 SSU, a foot valve is also recommended.

**NOTE:** If a foot valve (or check valve) is not used in the suction line, it may be necessary to refill the pump every time the unit is stopped and you wish to restart the pump. This depends on the length of time between starts and whether or not the impeller is wet enough to close cavities to affect a prime.

6. If solid contaminants are suspected in a liquid, place a filter in the suction line.
7. Be certain all suction piping connections are airtight.

**NOTE:** Assure airtight pipe connections with the use of a pipe joint sealant.

#### DISCHARGE

8. Attach discharge piping to the discharge outlet.

**⚠ WARNING** *Support pump and piping during assembly and after installation. Failure to do so may cause piping to break, pump to fail, motor bearing failures, etc., all of which can result in property damage and/or personal injury.*

**NOTE:** Should the pump need to be self-draining, the pump head should be mounted in the vertical position with the suction port facing down. When pumping high viscosity fluids, the vertical position can be used with the suction port facing up and the pump mounted under the source. Increasing the suction pipe size and eliminating bends and elbows also assists in pump-

ing high viscosity fluids. Max. viscosity is 500 SSU at 1725 RPM.

9. If a shut-off valve or handgun is required in discharge line, provide a pressure relief valve for pump protection.

**⚠ WARNING** *Shutting off discharge without providing pressure relief can cause extreme overpressure which can result in pump and/or motor failure. Do not exceed 25 PSI (or 60 feet of head) pump or system pressure.*

10. Operation under shut-off discharge conditions will overheat and damage pump and impeller.

**NOTE:** Globe valve or other restrictive valves should not be used as shut-off mechanism as they are restrictive in nature and will seriously affect pump performance.

11. After all piping and controls (not supplied with unit) have been installed, unit is ready for operation.

### Operation

**⚠ WARNING** *Do not run pump dry, as permanent damage to the pump impeller, seal, pump housing and wear plates will result. Suction pressure should never be greater than the discharge pressure. Dry running will result in immediate failure of impeller and cause extreme pump temperature (do not handle pump when hot). Impeller damage is not covered under warranty.*

1. All pumps must be primed before start-up and filled with fluid (See Figure 3). Never operate a pump unless it is secured to a solid foundation and all safety shields are installed.

Upon start-up, maintain a minimum of 15 PSI (1 BAR) operating pressure on the pump. This will allow any remaining air to be driven from the seal chamber and will ensure liquid circulation to the seal.

2. Flexible impeller pumps are built to very close tolerances and this

# SHERTECH® Bronze Pedestal Self-Priming Flexible Impeller Pumps

## Installation (Continued)

tolerance must not be altered. The liquids must, therefore, be free of all abrasives. Sand, silt, wettable powders, etc. must be avoided.

3. When pumping a more viscous (beyond 500 SSU) liquid; a slower speed, a larger pipe size pump, and possibly a larger motor should be selected.

**NOTE:** See performance chart for Max. Torque.

4. Recheck motor and pump rotation. Pump rotation is by-directional (See Figure 1).

## PRESSURE RELIEF VALVE

5. Standard models do not include a pressure relief valve. If discharge is going to be shut off, an external pressure relief valve should be installed.
6. Unit is ready for operation.

## Maintenance

**⚠ WARNING** *Make certain that the power source is disconnected before attempting to service or disassemble any components!*

*If the power disconnect is out of sight, lock it in the open position and tag to prevent application of power.*

## CLEANING

Clean the suction line filter at regular intervals.

## ELECTRIC MOTOR

Properly selected and installed, electric motors are capable of operating for years with minimal maintenance. Periodically clean dirt accumulations from open-type motors, especially in and around vent openings, preferably by vacuuming (avoid imbedding dirt in windings). Oil and maintain as recommended by motor manufacturer.

## GENERAL

Check the pump to motor shaft coupler alignment at regular intervals.

Periodically check that electrical connections are tight. Pump should be drained if placed in an area that is subject to freezing temperatures and should not be operated until temperature permits.

To store the pump, place a small quantity of light oil or some other storage preservative compatible with your application in the pump and rotate the shaft very slowly to work the oil throughout the gears and the body.

## PUMP REPAIR (Procedures for Models R30GN and R50GN - See Figures 2 and 6)

### DISASSEMBLY

**⚠ CAUTION** *Never use petroleum-based grease or oil with optional Neoprene impellers.*

- 1a. Remove six screws (Ref. No. 21) and six lockwashers (Ref. No. 22) securing cover (Ref. No. 4) to the pump body (Ref. No. 12). Pull the cover and bushing assembly off the drive shaft (Ref. No. 18).
- b. Remove and discard the gasket (Ref. No. 5).

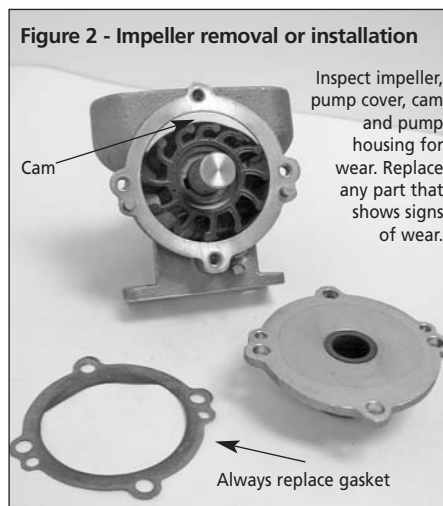

- c. To remove impeller (Ref. No. 8), gently grip the vanes on opposite sides of the impeller with two pair of pliers. Alternately pull on the impeller with the pliers or use two screwdrivers on opposite sides to pull it out.
- d. Inspect impeller for excessive wear and/or damage (See Figure 2).

**NOTE:** The impeller is a common wear item in this pump and frequent replacement is suggested. Impeller can become torn, distorted and overheated, becoming brittle. When this happens, impeller blade fragments can come off the impeller and be pumped downstream or block pump ports or plumbing. It is not recommended to flip around a used/worn impeller for reinstallation. (See Appendix 1 for illustrations of common impeller problems.)

- e. To remove the cam (Ref. No. 7), remove the screw (Ref. No. 6) that goes down through the top of the body between the intake and discharge ports.



- f. To remove the bearing housing (Ref. No. 14), seal assembly (Ref. Nos. 10 & 11), and shaft (Ref. No. 18) from the pump body (Ref. No. 12), remove the two screws (Ref. No. 20) and lockwashers (Ref. No. 22) from the bearing housing (Ref. No. 14) on the drive shaft end of pump body (Ref. No. 12) (See Figure 3).

## Models R30GN, R50GN and R102N

- g. Remove the woodruff key (Ref. No. 9), located on the side of the shaft (Ref. No. 12), by either of the following two methods: place a screwdriver on the woodruff key and tap lightly on the woodruff key with a mallet. Be careful not to damage the woodruff key. If this does not work, put the woodruff key in a soft vise, tighten, then pull up on the body (See Figure 4).

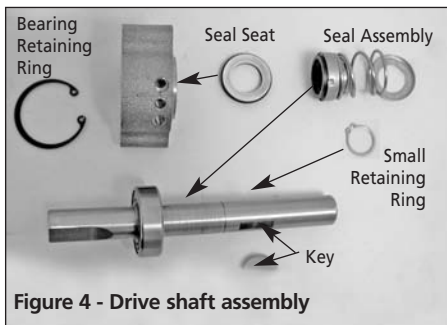

- ▲ CAUTION** *Do not damage the shaft.*
- h. Using a large snap ring pliers, remove the internal retaining ring (Ref. No. 16) from the bearing housing (Ref. No. 14). Using a small snap ring pliers, remove the retaining ring (Ref. No. 17) from the shaft (Ref. No. 18) at the seal end. While supporting the bearing housing (Ref. No. 14), press against the shaft from the impeller end. The mechanical seal (Ref. No. 10) will slide off the shaft (See Figure 4).
- i. Check the ball bearing (Ref. No. 15) for leakage or damage. Discard the bearing gasket (Ref. No. 13) and replace with a new one (See Figure 4).
- j. Inspect for leakage between the shaft (Ref. No. 18) and pump body (Ref. No. 12) at the drive end.
- k. To remove the seat assembly (Ref. No. 11), push a screwdriver through the bearing end and against the

rubber or backside of the seal seat (See Figure 4).

- 2a. Inspect drive shaft (Ref. No. 18). If drive shaft has scratches where mechanical seal (Ref. No. 10) is installed or if key slots are worn, replace shaft. If shaft is bent, replace as well (See Figure 4).
- b. Inspect the bushing (Ref. No. 3) in cover (Ref. No. 4) for wear and/or damage. If cover is worn (grooved or distorted), replace.
- c. The shaft should be installed into the carbon bushing (Ref. No. 3) to allow it to turn freely. It should not be tight or fit loosely. If it does, replace bushing.
- 3a. To replace the bushing (Ref. No. 3) in the cover (Ref. No. 4), carefully tap on a screwdriver with a mallet to chip the old bushing from the hole.
- b. Push new bushing (Ref. No. 3) into place, chamfer end first, until bushing is flush against cover (Ref. No. 4).

**▲ CAUTION** *Do not damage the brass cover.*

- 4a. Replace mechanical seal (Ref. Nos. 10 & 11) if removed, or is leaking between the body and shaft while the pump is running.
- b. Remove the shaft (Ref. No. 18). See above.
- c. Push or pry out the old mechanical seal seat (Ref. No. 11) by applying incremental pressure with a screwdriver from shaft bore at pump drive end in bearing retainer (Ref. No. 14). Do not damage seal bore in pump body. Discard old mechanical seal seat.

### ASSEMBLY

- 1a. Before installing the cam (Ref. No. 8), wipe off the old Permatex that has built up on the cam and penetrated

the impeller cavity. Hold the cam in place while installing and tightening the screw (Ref. No. 6) that goes between the intake and discharge ports in pump body (Ref. No. 12).

- b. Using a snap ring pliers, place the retaining ring (Ref. No. 17) onto the shaft (Ref. No. 18) and push down into the second groove from the drive shaft end. Push the ball bearing (Ref. No. 15) over the shaft (Ref. No. 18). Using a screwdriver, carefully push the bearing up against the retaining ring. Using a snap ring pliers, place the second retaining ring (Ref. No. 17) over the shaft and against the ball bearing (See Figure 4).
- c. From the woodruff key end of the shaft, push the seal seat (Ref. No. 11) over the shaft, rubber side first, into the bearing housing (Ref. No. 14) (See Figure 4). Do not use anything but water to lubricate the seal seat.
- ▲ CAUTION** *Be careful not to damage the white ceramic surface on the seat (or the black carbon face on seal). Damage could cause leakage.*
- d. Push the bearing (Ref. No. 15) and shaft assembly onto the bearing housing (Ref. No. 14). Using uniform pressure with a screwdriver, pop the retaining ring (Ref. No. 16) into place against the large internal bearing (Ref. No. 15) (See Figure 4).
- e. Push the mechanical seal (Ref. No. 10) over the shaft and down against the seal seat (Ref. No. 11) (See Figure 4). Do not use anything but water to lubricate seal on shaft.
- f. Using a snap ring pliers, place the third retaining ring (Ref. No. 17) on the shaft (Ref. No. 18). Simultaneously compress the seal assembly (Ref. No. 10) to allow the

# SHERTECH® Bronze Pedestal Self-Priming Flexible Impeller Pumps

## Maintenance (Continued)

retaining ring (Ref. No. 17) to snap into the groove on the shaft (Ref. No. 18) (See Figure 4).

- g. Press the woodruff key (Ref. No. 9) into the key way in the shaft (Ref. No. 18) using soft-jaw pliers or a soft vise (See Figure 4).

**CAUTION** *Be careful not to bump woodruff key against the stainless steel shaft.*

- h. Place a new small gasket (Ref. No. 13) onto the bearing housing (Ref. No. 14).
- i. Assemble the complete shaft, bearing and seal assembly onto the pump body (Ref. No. 12). Insert the two long screws and washers (Ref. Nos. 20 & 22) that secure the bearing housing (Ref. No. 14) to the pump body (Ref. No. 12) and tighten (See Figure 3).
- j. Lubricate impeller end of shaft with silicone or soapy water.
- k. Place a new impeller (Ref. No. 8) over the shaft (Ref. No. 18). Align the key (Ref. No. 9) in the shaft with the key way in the impeller, and push the impeller into the pump body (Ref. No. 12) with a twisting motion until impeller is inserted into pump body. Impeller should not be forced over key and should slide easily (See Figure 2).
- l. Rotate shaft (Ref. No. 18) several turns in direction of rotation to position impeller vanes.
- m. Attach a new gasket (Ref. No. 5) over the dowel pins (Ref. No. 1), then place cover on the gasket and fasten with screws and lockwashers (Ref. Nos. 21 & 22) (See Figure 2).
- n. All pumps must be primed before start-up and filled with fluid (See Figure 3). Never operate a pump unless it is secured to a solid foundation and all safety shields are installed.

## PUMP REPAIR

(Procedures for Model R102N - See Figures 2 and 6)

## DISASSEMBLY

**CAUTION** *Never use petroleum-based grease or oil with optional Neoprene impellers.*

- 1a. Remove four screws (Ref. No. 16) and four lockwashers (Ref. No. 17) securing cover (Ref. No. 10) to the body (Ref. No. 4). Pull the cover and bushing assembly off the drive shaft (Ref. No. 12) (See Figure 2).
- b. Remove and discard the gasket (Ref. No. 9) (See Figure 2).
- c. To remove impeller (Ref. No. 7), gently grip the vanes on opposite sides of the impeller with two pair of pliers. Alternately pull on the impeller with the pliers or use two screwdrivers on opposite sides to pull it out (See Figure 2).
- d. Inspect impeller for excessive wear and/or damage (See Figure 2).

**NOTE:** The impeller is a common wear item in this pump and frequent replacement is suggested. Impeller can become torn, distorted and overheated becoming brittle. When this happens, impeller blade fragments can come off the impeller and be pumped downstream or block pump ports or plumbing. It is not recommended to flip around a used/worn impeller for reinstallation. (See Appendix 1 for illustrations of common impeller problems.)

- e. To remove the cam (Ref. No. 6), remove the screw (Ref. No. 8) that goes down through the top of the body between the intake and discharge ports.
- f. Remove the woodruff key (Ref. No. 13), located on the side of the shaft (Ref. No. 12), by either of the following two methods: place a screwdriver on the woodruff key and tap lightly on the woodruff key with a

mallet. Be careful not to damage the woodruff key. If this does not work, put the woodruff key in a soft vise, tighten, then pull up on the body (See Figure 4).

**CAUTION** *Do not damage the shaft.*

- g. Using a large snap ring pliers, remove the internal retaining ring (Ref. No. 1) from the drive end side of the pump body (Ref. No. 4). Using a small snap ring pliers, remove the retaining ring (Ref. No. 3) from the shaft (Ref. No. 12) at the seal end. The mechanical seal (Ref. No. 5B) will slide off the shaft (Ref. No. 12). While supporting the pump body (Ref. No. 4), pull against the shaft from the drive end until shaft and bearing assembly are removed (See Figure 5).

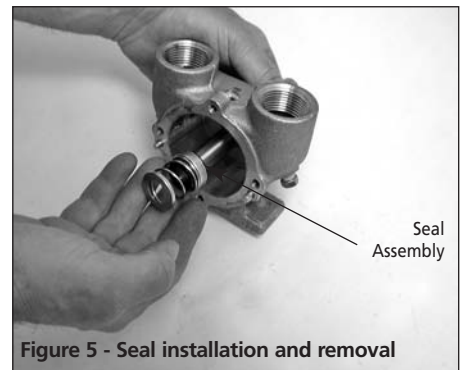

Figure 5 - Seal installation and removal

- h. Check the ball bearing (Ref. No. 2) for leakage or damage. Replace if necessary.
- i. To remove the seal seat assembly (Ref. No. 5A), push a screwdriver through the bearing end of pump body (Ref. No. 4) and against the rubber or backside of the seal seat.
- 2a. Inspect drive shaft (Ref. No. 12). If drive shaft has scratches where mechanical seal (Ref. No. 5B) is installed, or if key slots are worn, replace shaft. If shaft is bent, replace as well.

## Models R30GN, R50GN and R102N

- b. The shaft should be installed into the carbon bushing (Ref. No. 11) to allow it to turn freely. It should not be tight or fit loosely. If it does, replace bushing.
- 3a. To replace the bushing (Ref. No. 11) in the cover (Ref. No. 10), carefully tap on a screwdriver with a mallet to chip the old bushing from the hole.
- b. Push new bushing (Ref. No. 11) into place, chamfer end first, until bushing is flush against cover (Ref. No. 10).
- ▲ CAUTION** *Do not damage the brass cover.*
- 4a. Replace mechanical seal (Ref. Nos. 5A & 5B) if removed, or is leaking between the body and shaft while the pump is running.
- b. Remove the shaft (Ref. No. 12). See above.
- ASSEMBLY**
- 1a. Before installing the cam (Ref. No. 6), wipe off the old Permatex that has built up on the cam and penetrated the impeller cavity. Hold the cam in place while installing and tightening the screw (Ref. No. 8) that goes between the intake and discharge ports in the pump body (Ref. No. 4).
- b. Push the seal seat (Ref. No. 5A) into pump body (Ref. No. 4) rubber side first. Do not use anything but water to lubricate the seal seat.
- ▲ CAUTION** *Be careful not to damage the white ceramic surface on the seat (or the black carbon face on seal). Damage could cause leakage.*
- c. Inspect for leakage between the shaft (Ref. No. 12) and body (Ref. No. 4) at the drive end.
- d. Lubricate the drive and seal assembly (Ref. No. 5B) with water, and slide the new seal assembly over the impeller shaft (Ref. No. 12) with the carbon face first. Slide onto the shaft until the carbon seal face is compressed against the ceramic seal seat (Ref. No. 5A) (See Figure 5).
- e. Push drive shaft assembly (Ref. No. 12) with bearing (Ref. No. 2) and bearing retaining rings (Ref. No. 3) into the drive shaft side of the pump body (Ref. No. 4). Be sure to lubricate the drive shaft with water before pushing it through the new seal seat. After the bearing shaft assembly is pushed into the pump body (Ref. No. 4), reinstall snap ring (Ref. No. 1) into the pump body (Ref. No. 4).
- f. Using a snap ring pliers, place the third retaining ring (Ref. No. 3) on the shaft (Ref. No. 12). Simultaneously compress the seal assembly (Ref. No. 5B) to allow the retaining ring (Ref. No. 3) to snap into the groove on the shaft (Ref. No. 12).
- g. Press the woodruff key (Ref. No. 13) into the key way in the shaft (Ref. No. 12) using soft-jaw pliers or a soft vise.
- ▲ CAUTION** *Be careful not to bump woodruff key against the stainless steel shaft.*
- h. Lubricate impeller end of shaft with silicone or soapy water.
- i. Place a new impeller (Ref. No. 7) over the shaft (Ref. No. 12). Align the key (Ref. No. 13) in the shaft with the key way in the impeller, and push the impeller into the pump body (Ref. No. 4) with a twisting motion until impeller is inserted into pump body. Impeller should not be forced over key and should slide easily (See Figure 2).
- j. Rotate shaft (Ref. No. 12) several turns in direction of rotation to position impeller vanes.
- k. Attach a new gasket (Ref. No. 9) over the dowel pins (Ref. No. 15), then place cover on the gasket (Ref. No. 10) and fasten with screws and lockwashers (Ref. Nos. 16 & 17).
- l. All pumps must be primed before start-up and filled with fluid (See Figure 3). Never operate a pump unless it is secured to a solid foundation and all safety shields are installed.

## Contact a Shertech Distributor

Distributors can be found at [www.shertech.com](http://www.shertech.com) or [www.hyproindustrial.com](http://www.hyproindustrial.com)

(The factory only sells pumps and parts to distributors.)

Please provide following information:

- Model number
- Serial number (if any)
- Part description and number as shown in parts list

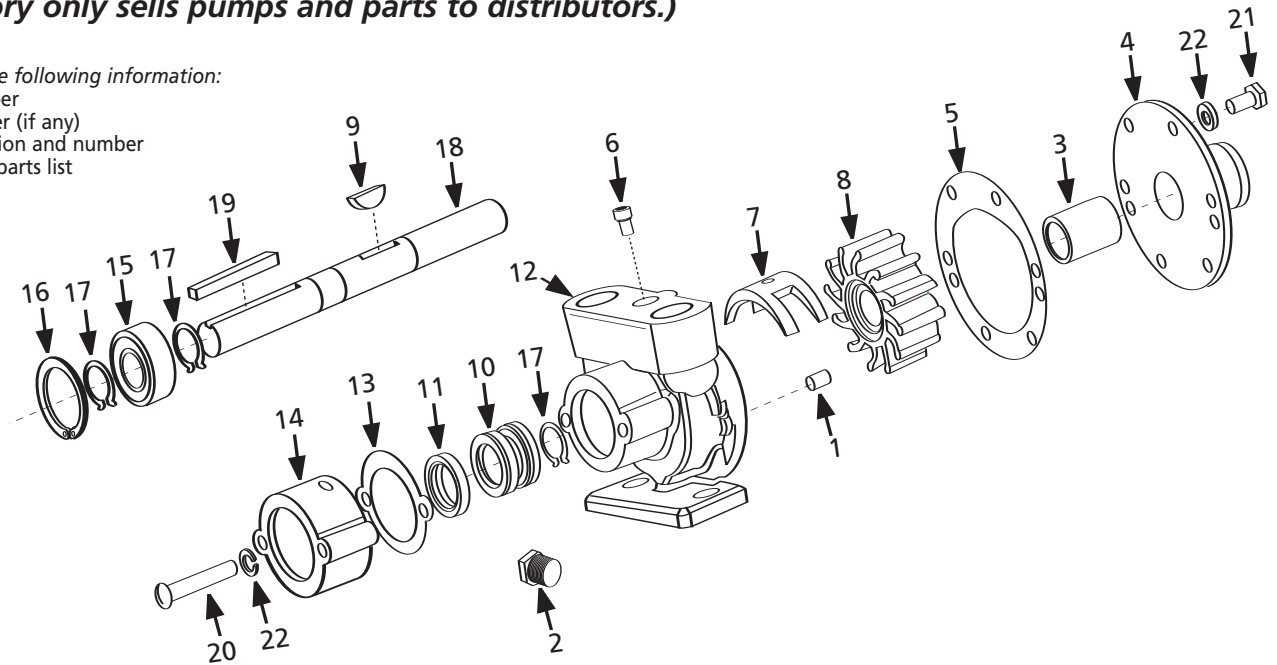

Figure 6

### Repair Parts List For R30GN and R50GN

Ref. No.	Description	Part No. For Model:		Qty.
		R30GN	R50GN	
1	Dowel Pin	01311	01311	2
2	Drain Plug (Bronze, Brass or Stainless Steel)	00336	00336	1
3	Bushing (Carbon Graphite)	0275-G	06333	1
4	Cover (Bronze or Brass)	10279	10094	1
5	Gasket (Vellumoid)	10286	10103	1
6	Cam Screw (Bronze, Brass or Stainless Steel)	10195	09919	1
7	Cam (Bronze or Brass)	10285	10072	1
8	Impeller (Nitrile, with Bronze, Brass or 300 Series SS insert)	12336S	21251S	1
Optional	Impeller (Neoprene, with Bronze, Brass or 300 Series SS insert)	10077S	09959S	1
9	Woodruff Key	10093	04432	1
10 & 11*	Mechanical Seal and Seat (Buna-N) Assembly	24833S	24843S	1
12	Pump Body (Bronze or Brass)	10596	10176	1
13	Gasket (Vellumoid)	10197	10171	1
14	Ball Bearing Housing (Bronze or Brass)	15103	15104	1
15	Ball Bearing	04306	04257	1
16	Retaining Ring	04303	04259	1
17	Retaining Ring	04304	04258	3
18	Shaft (303 Stainless Steel)	24832	10175	1
19	Key (Square)	13370	21437	1
20	Screw	05437	04265	2
21	Screw	18899	01482	4 or 6
22	Lockwasher	00343	12710	4 or 6

(\* ) Mechanical seal/seat assembly with carbon ceramic faces and 18-8 Stainless Steel components.

Manufacturer reserves the right to change parts without notification.

## Contact a Shertech Distributor

Distributors can be found at [www.shertech.com](http://www.shertech.com) or [www.hyproindustrial.com](http://www.hyproindustrial.com)

(The factory only sells pumps and parts to distributors.)

Please provide following information:

- Model number
- Serial number (if any)
- Part description and number as shown in parts list

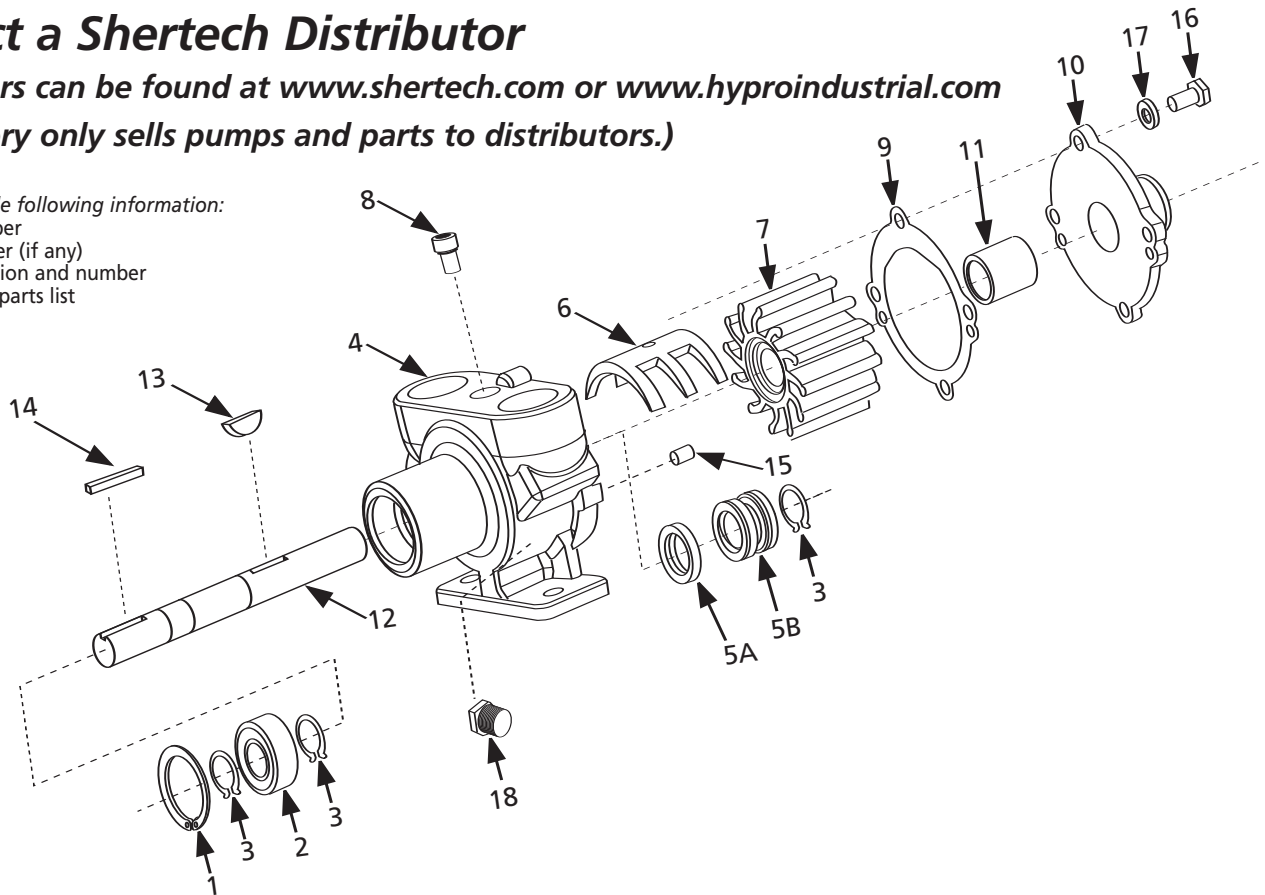

Figure 7

### Repair Parts List For R102N

Ref. No.	Description	Part No. For Model: R102N	Qty.
1	Retaining Ring	04259	1
2	Bearing	04257	1
3	External Retaining Ring	04258	3
4	Pump Body (Bronze or Brass)	18501	1
5*	Mechanical Seal (B) and Seat (A) (Buna-N) Assembly	24834S	1
6	Cam (Bronze or Brass)	10929	1
7	Impeller (Nitrile, with Bronze, Brass or 300 Series SS insert)	19317S	1
Optional	Impeller (Neoprene, with Bronze, Brass or 300 Series SS insert)	10615S	1
8	Cam Screw (Bronze, Brass or Stainless Steel)	10515	1
9	Gasket (Vellumoid)	10931	1
10	Cover (Bronze or Brass)	10182	1
11	Bushing (Carbon Graphite)	06333	1
12	Shaft (300 Series Stainless Steel)	24381	1
13	Woodruff Key (303 Series Stainless Steel or Brass)	04432	1
14	Key - Square	21437	1
15	Dowel Pin	01311	2
16	Screw	17845	4
17	Lockwasher	12170	4
18	Drain Plug (Bronze, Brass or Stainless Steel)	00336	2

(\* ) Mechanical seal/seat assembly with carbon ceramic faces and 18-8 Stainless Steel components.

Manufacturer reserves the right to change parts without notification.

# SHERTECH® Bronze Pedestal Self-Priming Flexible Impeller Pumps

## Appendix 1 - Impeller Pump Inspection, Common Problems and Operation

Shertech recommends replacing your impeller annually. Proper storage of the impellers during a prolonged lay-up can help maintain the life of the impeller.

Remove the impeller from the housing and store it in a cool, dark place. This will avoid the following:

- Copper bonding of the impeller to the housing
- Vanes "setting" into position as stored in the housing
- Ultraviolet deterioration

### Recommended inspection to be performed at any service interval:

- Impeller . . . . . Inspect for cracks or tears. Also, inspect for excessive abrasion of vane ends. Replace annually or if any of the conditions exist (see picture).
- Wear Plate . . . . . Inspect for wear, flatness, and pin for fatigue. Replace at minor and major pump rebuild or if wear is evident to maintain pump flow and suction performance.
- Cam . . . . . Replace at major pump rebuild or if pitting/wear is evident.
- Cover . . . . . Replace at major pump rebuild or if wear exists to maintain pump flow and suction performance.
- Mechanical Seal . . . . . Replace at minor and major pump rebuild or if leaking.
- Lip Seal . . . . . Replace at minor and major pump rebuild or if leaking.
- Shaft . . . . . Inspect for wear in area of lip seal and rubber impeller. Grooving of lip seal area or heavy fretting of the impeller end shaft will require shaft replacement.
- Bearing . . . . . Inspect for loss of grease, corrosion or rough rotation. Replace at major pump rebuild or if in doubt.

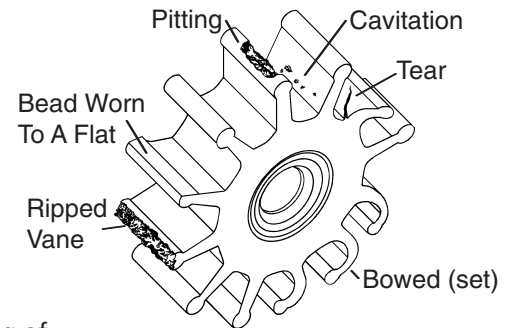

### Three tips to help you install your new Dayton impeller:

- Use a non-petroleum-based lubricant (silicone or soapy water) to help slide the impeller into the housing.
  - Install the impeller with a twisting motion onto the shaft. Never force an impeller onto the shaft.
  - Impeller must be able to move freely on the shaft to properly prime and function.
- (Use a small amount of non-petroleum-based lubricant to help hold the o-ring or gasket when replacing the cover.)

## Operation: How an Impeller Pump Works

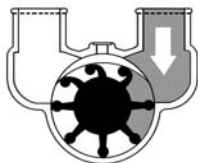

**1** A self-priming vacuum is created as the flexible impeller vanes straighten upon leaving the cam, drawing liquid into the pump.

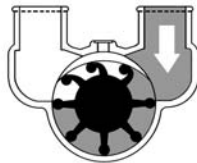

**2** The rotating impeller carries liquid from the inlet to the outlet port.

As a consequence of their design, flexible impeller pumps can pass fairly large solids.

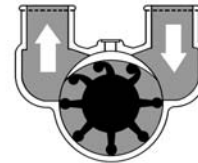

**3** When the flexible impeller vanes regain contact with the cam, they bend and the liquid is discharged from the pump in a uniform flow.

Liquids can be pumped in the opposite direction by reversing the rotation of the pump.



# Limited Warranty on **SHERTECH**® Bronze Self-Priming Flexible Impeller Pumps (Close-Coupled)

Hypro warrants to the original purchaser of its products (the "Purchaser") that such products will be free from defects in material and workmanship under normal use for the period of six (6) months, and accessories will be free from defects in material and workmanship under normal use for the period of ninety (90) days. Parts carry no warranty.

"Normal use" does not include use in excess of recommended maximum speeds, pressures, vacuums and temperatures, or use requiring handling of fluids not compatible with component materials. This warranty does not cover freight damage, freezing damage, pump or motor damage from incorrect wiring (if equipped with motor), normal wear and tear, or damage caused by misapplication, fault, negligence, alterations, dry running pump, or repair that affects the performance or reliability of the product.

**THIS WARRANTY IS EXCLUSIVE. HYPRO MAKES NO OTHER WARRANTY, EXPRESS OR IMPLIED, INCLUDING BUT NOT LIMITED TO ANY WARRANTY OF MERCHANTABILITY OR FITNESS FOR A PARTICULAR PURPOSE.**

Hypro's obligation under this warranty is, at Hypro's option, to either repair or replace the product upon return of the entire product to the Hypro factory in accordance with the return procedures set forth below. **THIS IS THE EXCLUSIVE REMEDY FOR ANY BREACH OF WARRANTY.**

**IN NO EVENT SHALL HYPRO BE LIABLE FOR ANY INCIDENTAL OR CONSEQUENTIAL DAMAGES OF ANY KIND, WHETHER FOR BREACH OF ANY WARRANTY, FOR NEGLIGENCE, ON THE BASIS OF STRICT LIABILITY, OR OTHERWISE.**

Only authorized distributors can return products for Warranty. Contact your distributor or visit [www.shertech.com](http://www.shertech.com) to find a distributor for product support.

Distributors can obtain an RMA # and contact person's name by contacting Hypro's customer service at 800-471-0460.

## Return Procedures for Distributors

All pumps or products must be flushed of any chemical (ref. OSHA Section 0910.1200 (d)(e)(f)(g)(h) and hazardous chemicals must be labeled before being shipped\* to Hypro for service or warranty consideration. Hypro reserves the right to request a Material Safety Data sheet from the Purchaser for any pump or product Hypro deems necessary. Hypro reserves the right to "disposition as scrap" pumps or products returned without authorization and/or which contain unknown substances, or to charge for any and all costs incurred for chemical testing and proper disposal of components containing unknown substances. Hypro requests this in order to protect the environment and personnel from the hazards of handling unknown substances.

Be prepared to give Hypro full details of the problem, including the following information:

1. Model number, sale record/invoice, purchase date and from whom you purchased your pump.
2. A brief description of the pump problem, including the following:

- Liquid pumped. State the pH and any non-soluble materials, and give the generic or trade name.
- Temperature of the liquid and ambient environment.
- Suction lift or vacuum (measured at the pump).
- Discharge pressure.
- Size, type, and mesh of the suction strainer.
- Abrasiveness or particulate size in fluids.
- Drive type (gas engine/electric motor; direct/belt drive; tractor PTO) and rpm of pump.
- Viscosity of fluid if other than water.
- Specific gravity of fluid if other than water.
- Elevation from the pump to the discharge point.
- Size and material of suction and discharge line.

Hypro may request additional information and may require a sketch to illustrate the problem. Distributors should contact the factory to receive a return material authorization before sending the product. All pumps returned for warranty work should be sent shipping charges prepaid to:

[RMA# and Contact Person]  
HYPRO  
375 Fifth Avenue NW  
New Brighton, Minnesota 55112

**NOTE:** Hypro reserves the right to "disposition as scrap" pumps or products returned without authorization.

\*Carriers, including U.S.P.S., airlines, UPS, ground freight, etc., require specific identification of any hazardous materials being shipped. Failure to do so may result in a substantial fine and/or prison term. Check with your shipping company for specific instructions.

# SHERTECH®



# HYPRO®

Pentair Water

**INDUSTRIAL PRODUCTS GROUP**

375 Fifth Avenue NW • New Brighton, MN 55112

Phone: (651) 766-6300 • 800-471-0460 • Fax: 800-672-7023

[www.shertech.com](http://www.shertech.com) • [www.hyproindustrial.com](http://www.hyproindustrial.com)