

Please read and save this Repair Parts Manual. Read this manual and the General Operating Instructions carefully before attempting to assemble, install, operate or maintain the product described. Protect yourself and others by observing all safety information. The Safety Instructions are contained in the General Operating Instructions. Failure to comply with the safety instructions accompanying this product could result in personal injury and/or property damage! Retain instructions for future reference.

SHURflo Small Close-Coupled DC Centrifugal Pumps

316 Stainless Steel and Bronze Models

Refer to form L-4082 for General Operating and Safety Instructions.

Description

SHURflo close-coupled, 316 stainless steel and bronze, semi-open impeller centrifugal models pump continuously, producing high flow rates under low-head conditions. Designed for continuous low pressure circulation and transfer of nonflammable liquids, utility, boiler feed, general transfer, filtration, cooling towers, condensate return, marine applications, fountains, boosters, water circulation, irrigation, spraying systems, jockey pump service, chemical processing, aggressive liquid applications and other general purpose pumping compatible with pump component materials where no suction lift or no self-priming is required.

- Capacities to 24 GPM, heads to 25 ft.
- DC motor voltages are available in 12, 24 and 36 volts.
- Clog-resistant, semi-open metallic impellers (Bronze models have a bronze/brass impeller; Stainless Steel models have a 316 stainless impeller.)
- Pumps feature maintenance-free ball bearings and an easily accessible front drain plug for draining liquid.
- Maximum casing working pressure is 100 PSI.
- Standard pump models will handle specific gravities to 1.1. Higher specific gravity fluids are not recommended.
- Pumps are capable of fluid viscosities to 50 SSU at standard motor speeds. Higher viscosity fluids are not recommended.
- 3/4" female NPT inlet and outlet ports.
- Discharge port can be rotated at 90-degree intervals.
- Stainless steel and bronze models handle temperatures from 40° to 180° F.
- Seals: Bronze models are equipped with a Viton lip seal and Viton o-ring, and Stainless Steel models are equipped with a carbon ceramic viton mechanical seal having 316 stainless steel components and Viton o-rings.

316 STAINLESS STEEL CENTRIFUGAL PUMP WITH DC MOTOR – Wet-end components are constructed of 316 and 300 series stainless steel, Viton, carbon and ceramic.

BRONZE CENTRIFUGAL PUMP WITH DC MOTOR – Wet-end components are constructed of bronze, brass, Viton and 300 series stainless steel.

 Do not use to pump flammable or explosive fluids such as gasoline, fuel oil, kerosene, etc. Do not use in flammable and/or explosive atmospheres. When pumping hazardous or dangerous materials, use only in room or area designated for that purpose. For your protection, always wear proper clothing, eye protection, etc. in case of any malfunction. For proper handling techniques and cautions, contact your chemical supplier, insurance company and local agencies (fire dept., etc.). Failure to comply with this warning could result in personal injury and/or property damage.

CAUTION Pumps are not self-priming and cannot suction lift, flooded inlet is required. If inlet is not flooded when the pump is running, seal failure will result and is not covered under the manufacturer's warranty.

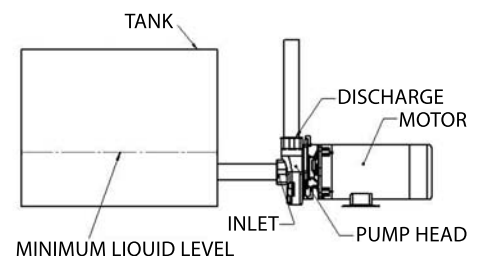

CENTRIFUGAL PUMP WITH FLOODED SUCTION
NON-SELF PRIMING
DO NOT RUN DRY

SHURflo Small Close-Coupled DC Centrifugal Pumps 316 Stainless Steel and Bronze Models

Model Ordering Codes and Options



Model Number: COMSV012D

Example Model: COMSV012D

1st	2nd	3rd	4th	5th	6th
Series	Mounting	Material	Seal (Mech)	Impeller Size (Ports)	Motor Options
CO: Centrifugal Semi-Open Impeller	M: Motor Mount	S: 316 Stainless Steel B: Bronze	V: Viton Mechanical Seal (for SS models only) L: Viton Lip Seal (for bronze models only)	0 (3/4" - 3/4")	12D: 12 Volt DC 24D: 24 Volt DC 36D: 36 Volt DC

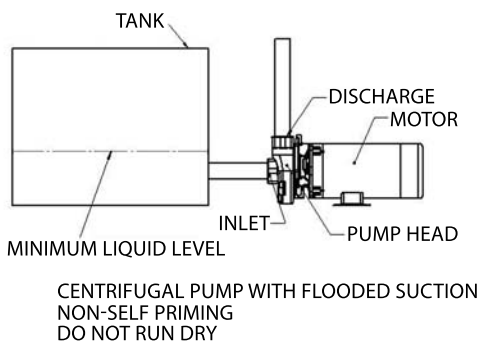

NOTE: Not all order code combinations (configurations) are standard models available from the manufacturer. Custom model configurations may require ordering standard components and/or optional parts that will need to be assembled by the customer.

Manufacturer reserves the right to change model order codes, standard models, specifications, and performance without notification.

Stainless Steel Models COMSV012D, COMSV024D, COMSV036D Bronze Models COMBL012D, COMBL024D, COMBL036D

Performance

Model	Inlet Port (NPT)*	Outlet Port (NPT)*	GPM Pumping Water at 70° F @ Total Feet of Head				Shutoff (Feet)
			Free Flow	5	10	15	
Stainless Steel Motor-Mounted Models							
COMSV012D	3/4"	3/4"	21	18	16	11	22
COMSV024D	3/4"	3/4"	21	18	16	11	22
COMSV036D	3/4"	3/4"	21	18	16	11	22
Bronze Motor-Mounted Models							
COMBL012D	3/4"	3/4"	21	18	16	11	22
COMBL024D	3/4"	3/4"	21	18	16	11	22
COMBL036D	3/4"	3/4"	21	18	16	11	22

Test data taken on water at 70° F (to convert data to PSI, divide feet of head by 2.31).

Pump performance when pump is new. As pump wears, the performance will decrease.

(*) Female NPT inlet and outlet (in inches).

NOTES: Consult tables on HP adders and speed recommendations for high viscosity fluids. The pump relationship between volume (GPM), pressure (PSI), speed (RPM) and horsepower is shown on Performance Chart in Shurflo Motor Manual form L-4082. When pumping a more viscous liquid; a slower speed, a larger pipe size pump, and possibly a larger motor should be selected.
Max. Viscosity = 50 SSU with the motor supplied (at 1.1 specific gravity).

Max. Specific Gravity = 1.1.

Manufacturer reserves the right to change performance without notification.

SHURflo Small Close-Coupled DC Centrifugal Pumps

316 Stainless Steel and Bronze Models

Specifications

Model	HP*	Type	DC Motor Voltage	Shaft Rotation**	Full Load Amps	Max. Amps	Overload Protection***	Pump Shaft Size	Motor Shaft Type	Ports (NPT)	PUMP CONSTRUCTION (Wet End)				Ship Wt. (lbs.)
											Body/Adapter & Cover Castings	Impeller	Shaft	Seals & O-Rings	
Stainless Steel Motor-Mounted Models															
COMSV012D	1/8	TENV	12	CW	8.5	10.5	Fuse	8mm	Flat	3/4"	316 SS	316 SS	300 SS	Viton†	4.1
COMSV024D	1/8	TENV	24	CW	5.4	7.8	Fuse	8mm	Flat	3/4"	316 SS	316 SS	300 SS	Viton†	4.1
COMSV036D	1/8	TENV	36	CW	3.2	5.0	Fuse	8mm	Flat	3/4"	316 SS	316 SS	300 SS	Viton†	4.1
Bronze Motor-Mounted Models															
COMBL012D	1/8	TENV	12	CW	8.5	10.5	Fuse	8mm	Flat	3/4"	BR/BZ	BR/BZ	300 SS	Viton‡	4.3
COMBL024D	1/8	TENV	24	CW	5.4	7.8	Fuse	8mm	Flat	3/4"	BR/BZ	BR/BZ	300 SS	Viton‡	4.3
COMBL036D	1/8	TENV	36	CW	3.2	5.0	Fuse	8mm	Flat	3/4"	BR/BZ	BR/BZ	300 SS	Viton‡	4.3

TENV = Totally-Enclosed Non-Ventilated SS = Stainless Steel BZ = Bronze BR = Brass

(*) Approximate HP

(**) Standing behind the motor

(***) Replaceable fuse

(†) Mechanical seal: Standard shaft seal also contains 316 series stainless steel, carbon and ceramic.

(‡) Lip seal: Standard shaft seal also contains 300 series stainless steel.

NOTES: Driver data is subject to change without notice; see label on driver for actual information.

Manufacturer reserves the right to change specifications without notification.

All dimensions are in inches unless otherwise specified.

Stainless Steel Models COMSV012D, COMSV024D, COMSV036D Bronze Models COMBL012D, COMBL024D, COMBL036D

Dimensions

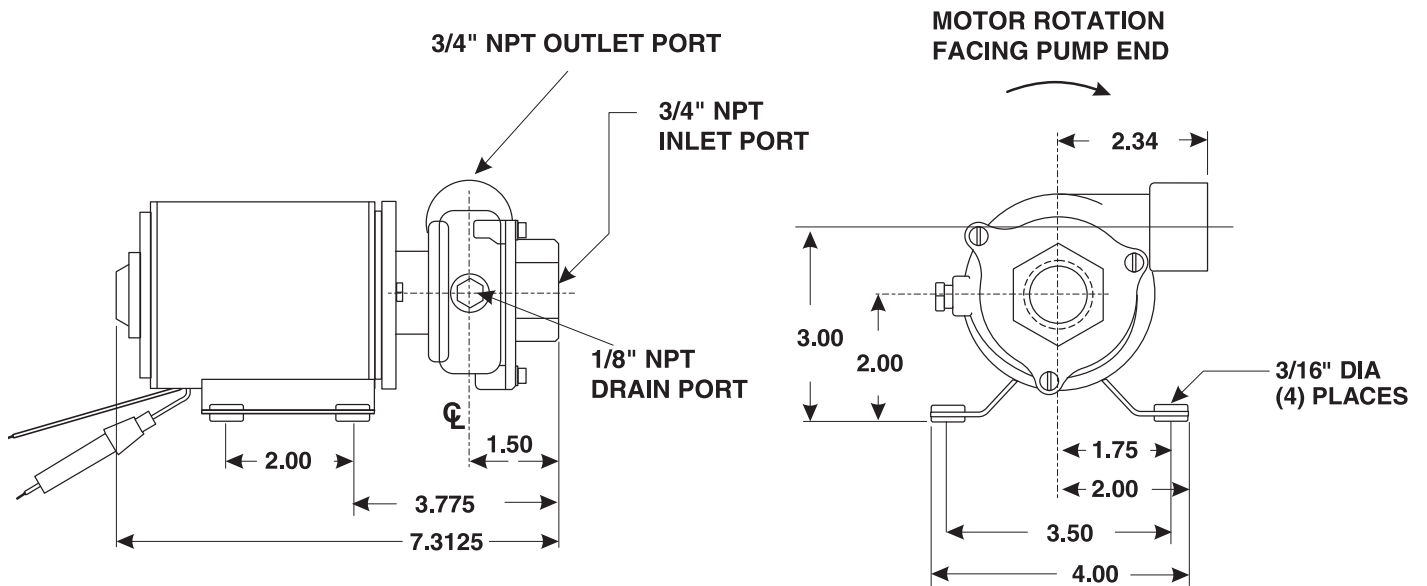

Figure 1 – 316 Stainless Steel Centrifugal Pump with DC Motor (Mounting dimensions in inches)

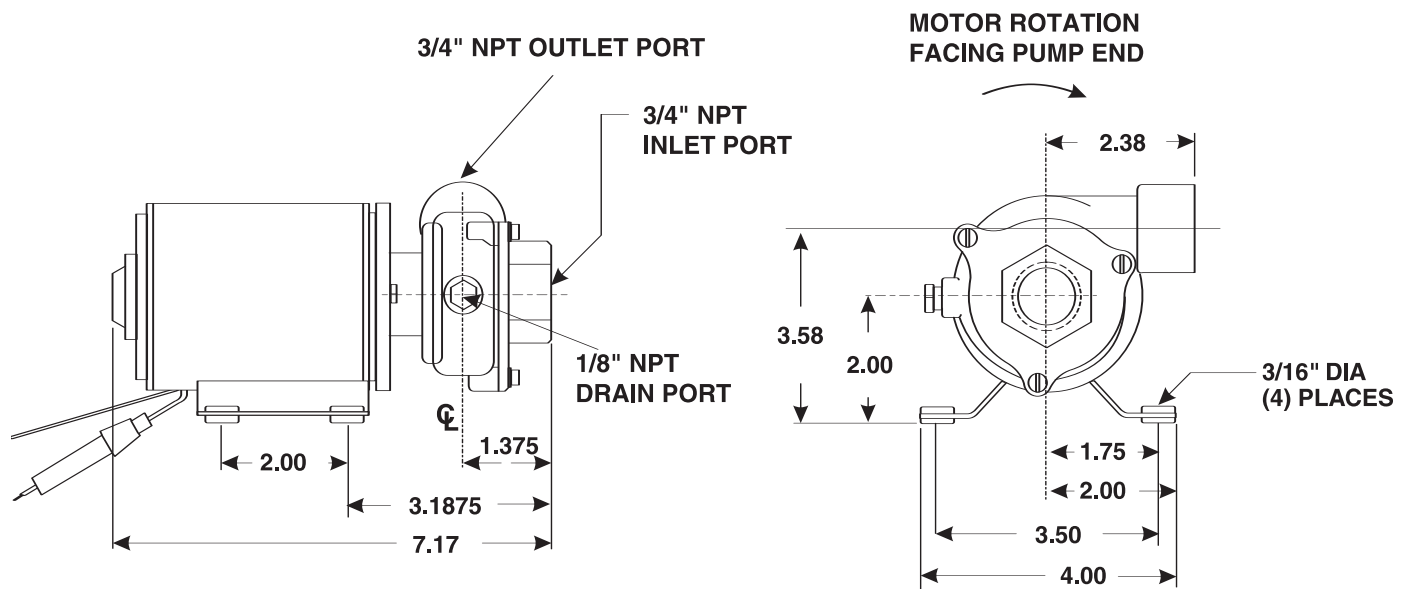

Figure 2 – Bronze Centrifugal Pump with DC Motor (Mounting dimensions in inches)

SHURflo Small Close-Coupled DC Centrifugal Pumps 316 Stainless Steel and Bronze Models

⚠ WARNING Check motor. It is equipped with a overload protection fuse which may restart unexpectedly when replaced (see specifications chart). Fuse blowing is an indication of motor overloading as a result of operating the pump (see pump specifications), too high of viscosity, too high of specific gravity, excessively high or low voltage, inadequate wiring, incorrect motor connections, too small a motor (sized incorrectly, not enough HP), or a defective motor or pump.

Do not handle pump with wet hands or when standing in water. Failure to follow the General Safety Information and all warnings could result in fatal electrical shock!

Installation

IMPORTANT: The pump must be mounted in a dry location. The motor is not waterproof, therefore it must not be submerged. The unit can be operated in any position, however, vertically mounting the pump with motor in the bottom position may result in motor failure. Mount the pump so that water dripping from a loose port connection will not wet the motor. The pump head

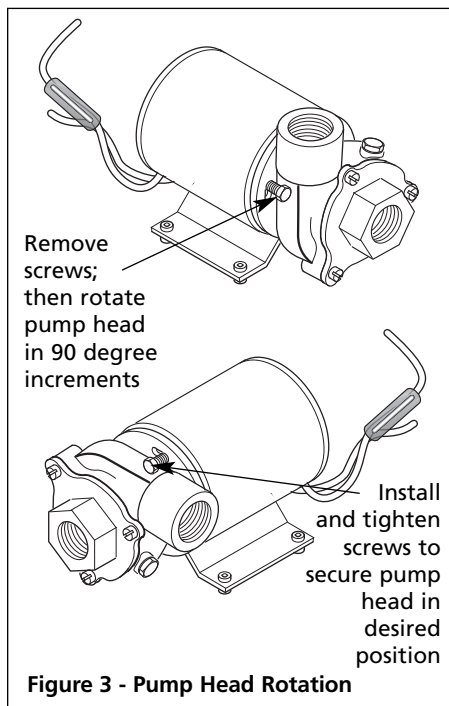

may be mounted at 90 degree increments on the motor to allow mounting as needed (See Figure 3).

⚠ CAUTION A seacock must be used between the hull inlet fitting and pump on below water line installations.

ELECTRICAL CONNECTIONS

⚠ WARNING Loose or inadequate wire connections can spark, resulting in an explosion, resulting in property damage, injury, or death.

Positive terminal of the battery is connected to an overload protected distribution panel (See Figure 4).

The red wire with fuse holder is connected to the distribution panel (See Figure 4).

The black wire is connected to the negative (-) terminal of the battery (See Figure 4).

NOTE: For proper operation, the motor must rotate clockwise when viewed from the pump end. The proper sized fuse has been installed in the fuse holder. Should this fuse blow, replace with the same size fuse after determining the reason for the blown fuse.

Operation

⚠ WARNING Do not run pump dry, as permanent damage to the pump and seal will result. Suction pressure should never be greater than the discharge pressure. Seal damage is not covered under warranty.

The pump may run against a closed outlet. Avoid long term shut-off conditions to prevent possible seal damage. Small particles will pass through the pump, but an intake strainer should be fitted if pump clogging is encountered.

⚠ CAUTION Motor runs hot, above 180°, so avoid touching the motor case. Contact during operation may cause a burn.

Maintenance

⚠ WARNING Make certain that the power source is disconnected before attempting to service or disassemble any components!

If the power disconnect is out of sight, lock it in the open position and tag to prevent application of power.

CLEANING

Check all electrical and plumbing connections periodically. In salt water applications, corrosion of the electrical

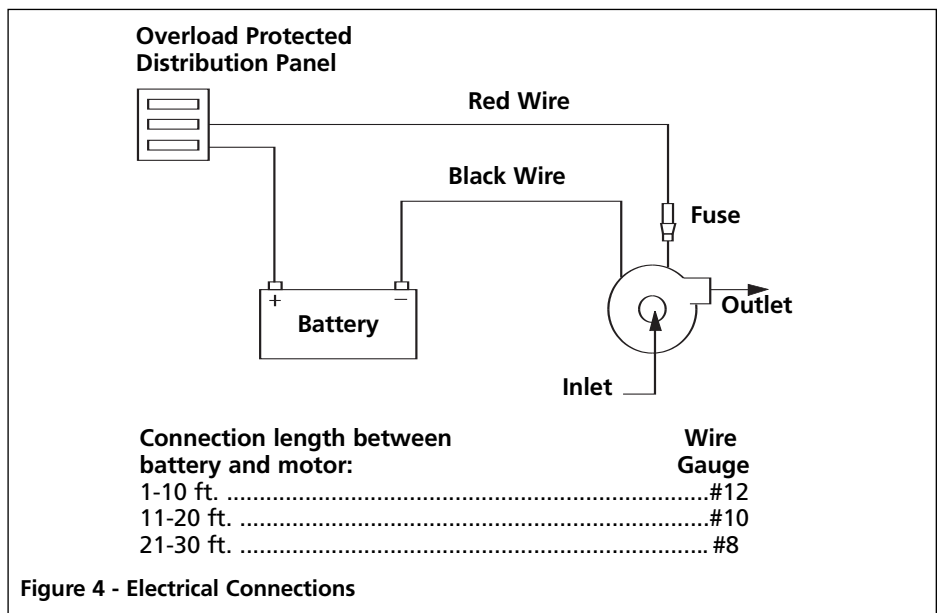

Stainless Steel Models COMSV012D, COMSV024D, COMSV036D Bronze Models COMBL012D, COMBL024D, COMBL036D

connections can cause a loss of performance or non-operation. The motor should be protected with a corrosion-inhibiting spray. Any rust should be removed and the motor repainted.

Gumming or corrosion inside the pump can be prevented by thoroughly flushing the pump clean with water or a liquid that will neutralize the liquid that has been pumped. For many liquids, a solution of one gallon of ammonia mixed with six gallons of water works the best.

To prevent rust or corrosion, first clean the pump as described for gumming for corrosion prevention; then, flush the pump with a permanent-type automotive radiator antifreeze containing a rust inhibitor. Use a 50-50 solution of antifreeze and water. After this flushing, drain and plug the pump ports to prevent air from entering the pump during storage. Cleaning and rust protection should be performed any time the pump will be stored for periods longer than two days.

PUMP REPAIR

(Procedures for Stainless Steel Models - See Figures 5, 6, 7 and 9)

DISASSEMBLY

1. Remove cover screws (Ref. No. 1), cover (Ref. No. 2), and o-ring (Ref. No. 1); then discard the old o-ring.
2. Remove pipe plug (Ref. No. 5) on the side of the housing (Ref. No. 6), and rotate the impeller (Ref. No. 9) so the set screw (Ref. No. 3) aligns with the plug hole.

CAUTION *The impeller is spring loaded. Always wear safety goggles when working with spring of tension-loaded fasteners or devices.*

3. Insert an allen wrench through the plug hole and loosen the impeller set screw (Ref. No. 3); then remove the impeller (Ref. No. 9).

4. Remove and discard the three components of the mechanical seal (Ref. No. 7).
5. Remove screws securing the housing to the motor (Ref. No. 10); then remove the housing (Ref. No. 6).

REASSEMBLY

1. Press the new ceramic seal into the housing with the ceramic portion of the ceramic seal facing away from the motor (See Figure 5).

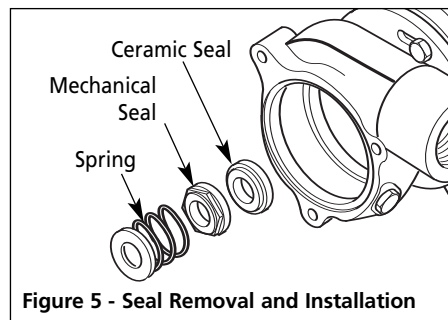

NOTE: Installing a new seal is always recommended when pump is disassembled to the point of seal removal. The precision carbon/ceramic faces on the mechanical seal are easily damaged. Handle your repair seal carefully. Do not touch the carbon/ceramic seal faces.

2. Using the two hex head screws (Ref. No. 4), secure the housing (Ref. No. 6) to the motor (Ref. No. 10).
3. Slide the new mechanical seal (Ref. No. 7) and the new spring onto the motor shaft (Ref. No. 10).

NOTE: Apply a drop of a blue anaerobic thread-locking compound to all threaded fasteners that do not require lock washers.

NOTE: Do not tighten the set screw (Ref. No. 3).

4. Align the set screw (Ref. No. 3) in the impeller (Ref. No. 9) with the flat on the motor shaft and slide the impeller onto the shaft until it con-

tacts the rear of the mechanical seal (Ref. No. 7).

5. Place the spacer tool (can be created using a piece of light cardboard about 0.020" thick) over the impeller as shown (See Figure 5).

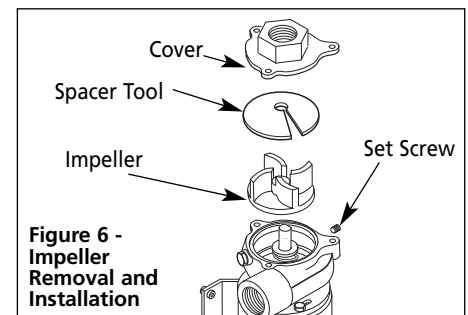

6. Position the cover (Ref. No. 2) in place on the housing (Ref. No. 6), and while pressing down on the cover, tighten the set screw (Ref. No. 3); then install the plug that was removed in Step 2 during disassembly (See Figure 6).

7. Remove the cover (Ref. No. 2) and discard the spacer tool.
8. Apply a thin coat of oil to the new o-ring (Ref. No. 8); then install the new o-ring onto the cover (See Figure 7).

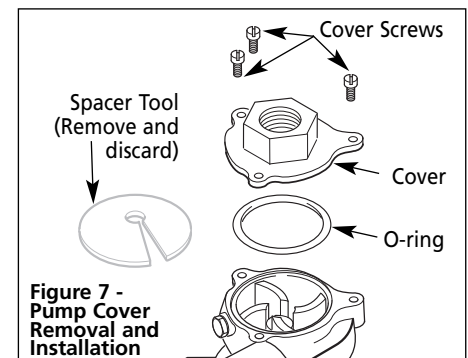

9. Align the cover with the housing and secure it to the cover using the three cover screws (Ref. No. 1) (See Figure 7).

SHURflo Small Close-Coupled DC Centrifugal Pumps 316 Stainless Steel and Bronze Models

Maintenance (Continued)

10. All pumps must be primed before start-up and filled with fluid. Never operate a pump unless it is secured to a solid foundation and all safety shields are installed.

⚠ WARNING *Do not run pump dry, as permanent damage to the pump and seal will result. Suction pressure should never be greater than the discharge pressure. Seal damage is not covered under warranty.*

PUMP REPAIR

(Procedures for Bronze Models -
See Figures 6, 7, 8 and 10)

DISASSEMBLY

1. Remove cover screws (Ref. No. 1), cover (Ref. No. 2), and o-ring (Ref. No. 8); then discard the old o-ring (See Figure 7).
2. Remove pipe plug (Ref. No. 5) on side of housing (Ref. No. 6), and rotate the impeller (Ref. No. 9) so the set screw (Ref. No. 3) aligns with the plug hole.
3. Insert an allen wrench through the plug hole and loosen the impeller set screw (Ref. No. 3); then remove the impeller (Ref. No. 9).

4. Remove screws securing the housing (Ref. No. 6) to the motor (Ref. No. 9); then remove the housing (Ref. No. 6).
5. From the inside of the housing (Ref. No. 6), insert a dowel into the seal area and press the seal (Ref. No. 7) out of seal bore; then discard the seal and inspect the motor shaft for signs of wear. If the motor shaft is worn, the motor must be replaced.

REASSEMBLY

1. From the rear of the housing (Ref. No. 6), press the seal (Ref. No. 7) into the seal bore with the lip angled toward pump cavity.
2. Apply a small amount of grease to the motor shaft in the area where the seal contacts it.
3. Slide the housing onto the shaft and secure it to the motor with the two hex head screws (Ref. No. 4).
4. Align the set screw (Ref. No. 3) with the flat on the motor shaft and slide the impeller (Ref. No. 9) onto the shaft until it contacts the rear of the housing (Ref. No. 6).

NOTE: Apply a drop of a blue anaerobic thread-locking compound to all threaded fasteners that do not require lock washers.

5. Slide the impeller (Ref. No. 9) forward 1/32" to 1/16" and secure it with the set screw (Ref. No. 3); then rotate the impeller (Ref. No. 9) by hand to ensure that it does not rub on the housing (Ref. No. 6).
6. Reinstall the pipe plug (Ref. No. 5) in the housing (Ref. No. 6).
7. Clean the contact surfaces of the cover (Ref. No. 2) and housing (Ref. No. 6).
8. Apply a thin coat of oil to the new o-ring (Ref. No. 8); then install the new o-ring onto the cover (Ref. No. 2).
9. Align the cover with the housing and secure it to the cover using the three cover screws (Ref. No. 1) (See Figure 7).
10. All pumps must be primed before start-up and filled with fluid. Never operate a pump unless it is secured to a solid foundation and all safety shields are installed.

⚠ WARNING *Do not run pump dry, as permanent damage to the pump and seal will result. Suction pressure should never be greater than the discharge pressure. Seal damage is not covered under warranty.*

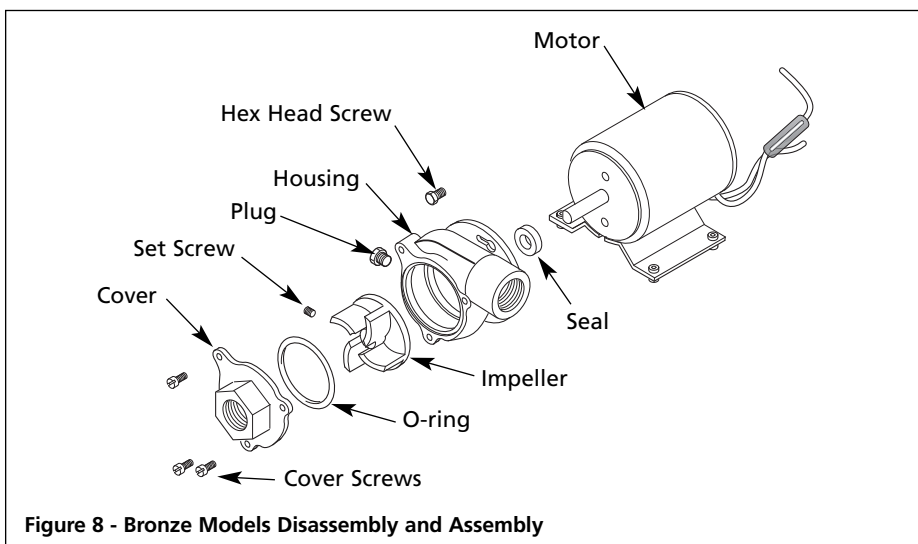

To order parts, contact a SHURflo Distributor or Order Direct.
Distributors can be found at www.shurfloindustrial.com.

Please provide following information:

- Model number
- Serial number (if any)
- Part description and number as shown in parts list

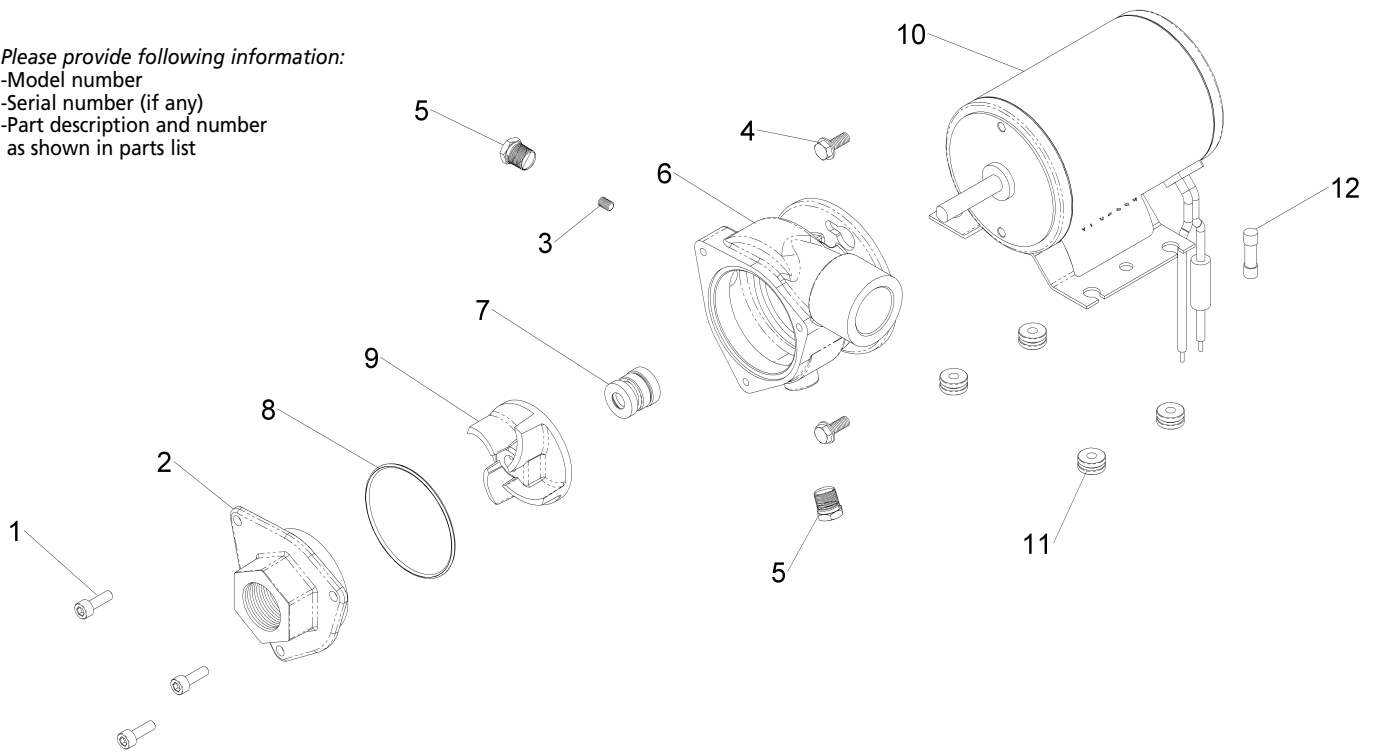

Figure 9 - Stainless Steel Models

Repair Parts List For Stainless Steel Models COMSV012D, COMSV024D and COMSV036D

Ref. No.	Description	Part No. For Model:			Qty.
		COMSV012D	COMSV024D	COMSV036D	
1	Cover Screw	0210-0124	0210-0124	0210-0124	3
2	Cover (316 SS)	23660	23660	23660	1
3	Screw Set	19929	19929	19929	1
4	Hex Head Screw	2210-0123	2210-0123	2210-0123	2
5	Pipe Plug (316 SS)	21059	21059	21059	2
6	Housing (316 SS)	23627	23627	23627	1
7	Mechanical Seal Assembly*	23665S	23665S	23665S	1
8	O-Ring (Viton)	19898	19898	19898	1
9	Impeller (316 SS)	23659	23659	23659	1
10	Motor (TENV)	23697S	23802S	23661S	1
11	Grommet	21138	21138	21138	4
12	Fuse	24554	24618	24619	1

TENV = Totally-Enclosed Non-Ventilated SS = Stainless Steel

(*) Mechanical seals have carbon ceramic wearing faces and 316 Stainless Steel spring components with Viton elastomers.

Manufacturer reserves the right to change parts without notification.

To order parts, contact a SHURflo Distributor or Order Direct.
Distributors can be found at www.shurfloindustrial.com.

Please provide following information:

- Model number
- Serial number (if any)
- Part description and number as shown in parts list

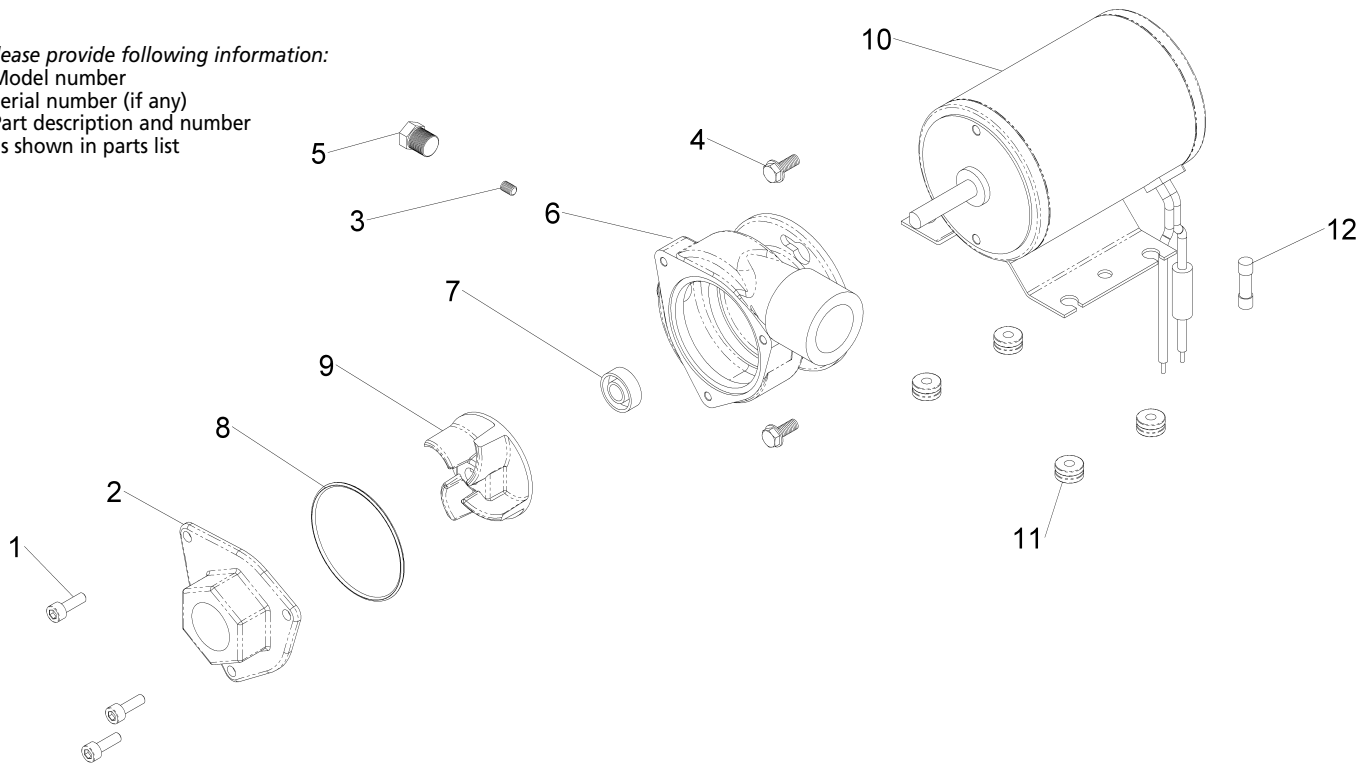

Figure 10 - Bronze Models

Repair Parts List For Bronze Models COMBL012D, COMBL024D and COMBL036D

Ref. No.	Description	Part No. For Model:			Qty.
		COMBL012D	COMBL024D	COMBL036D	
1	Cover Screw	0210-0124	0210-0124	0210-0124	3
2	Cover (Bronze/Brass)	19893	19893	19893	1
3	Screw Set	19929	19929	19929	1
4	Hex Head Screw	2210-0123	2210-0123	2210-0123	2
5	Pipe Plug (Bronze/Brass or 300 Series SS)	00336	00336	00336	2
6	Housing (Bronze/Brass)	19891	19891	19891	1
7	Lip Seal (Viton)*	19928	19928	19928	1
8	O-Ring (Viton)	19898	19898	19898	1
9	Impeller (Bronze/Brass)	19892	19892	19892	1
10	Motor (TENV)	23697S	23802S	23661S	1
11	Grommet	21138	21138	21138	4
12	Fuse	24554	24618	24619	1

TENV = Totally-Enclosed Non-Ventilated SS = Stainless Steel

(*) Lip seals have 300 Series Stainless Steel spring components with Viton elastomers.

Manufacturer reserves the right to change parts without notification.

Limited Warranty on SHURflo Small Close-Coupled DC Centrifugal Pumps 316 Stainless Steel and Bronze Models

SHURflo warrants to the original purchaser of its products (the "Purchaser") that such products will be free from defects in material and workmanship under normal use for the period of six (6) months, and accessories will be free from defects in material and workmanship under normal use for the period of ninety (90) days.

"Normal use" does not include use in excess of recommended maximum speeds, pressures, vacuums and temperatures, or use requiring handling of fluids not compatible with component materials. This warranty does not cover freight damage, freezing damage, normal wear and tear, or damage caused by misapplication, fault, negligence, alterations, or repair that affects the performance or reliability of the product.

THIS WARRANTY IS EXCLUSIVE. SHURflo MAKES NO OTHER WARRANTY, EXPRESS OR IMPLIED, INCLUDING BUT NOT LIMITED TO ANY WARRANTY OF MERCHANTABILITY OR FITNESS FOR A PARTICULAR PURPOSE.

SHURflo's obligation under this warranty is, at SHURflo's option, to either repair or replace the product upon return of the entire product to the SHURflo factory in accordance with the return procedures set forth below. **THIS IS THE EXCLUSIVE REMEDY FOR ANY BREACH OF WARRANTY.**

IN NO EVENT SHALL SHURflo BE LIABLE FOR ANY INCIDENTAL OR CONSEQUENTIAL DAMAGES OF ANY KIND, WHETHER FOR BREACH OF ANY WARRANTY, FOR NEGLIGENCE, ON THE BASIS OF STRICT LIABILITY, OR OTHERWISE.

Only authorized distributors can return products for Warranty. Contact your distributor or visit www.shurfloindustrial.com to find a distributor for product support.

Distributors can obtain an RMA # and contact person's name by contacting SHURflo's customer service at 800-854-3218 (Ext. 6788 or Ext. 6651).

Return Procedures for Distributors

All pumps or products must be flushed of any chemical (ref. OSHA Section 0910.1200 (d)(e)(f)(g)(h) and hazardous chemicals must be labeled before being shipped* to SHURflo for service or warranty consideration. SHURflo reserves the right to request a Material Safety Data sheet from the Purchaser for any pump or product SHURflo deems necessary. SHURflo reserves the right to "disposition as scrap" pumps or products returned which contain unknown substances, or to charge for any and all costs incurred for chemical testing and proper disposal of components containing unknown substances. SHURflo requests this in order to protect the environment and personnel from the hazards of handling unknown substances.

Be prepared to give SHURflo full details of the problem, including the following information:

1. Model number, purchase date and from whom you purchased your pump.

2. A brief description of the pump problem, including the following:

- Liquid pumped. State the pH and any non-soluble materials, and give the generic or trade name.
- Temperature of the liquid and ambient environment.
- Suction lift or vacuum (measured at the pump).
- Discharge pressure.
- Size, type, and mesh of the suction strainer.
- Drive type (gas engine/electric motor; direct/belt drive; tractor PTO) and rpm of pump.
- Viscosity (of oil, or other than water weight liquid).
- Elevation from the pump to the discharge point.
- Size and material of suction and discharge line.

SHURflo may request additional information, and may require a sketch to illustrate the problem. Distributors should contact the factory to receive a return material authorization before sending the product. All pumps returned for warranty work should be sent shipping charges prepaid to:

[RMA# and Contact Person]
SHURflo
375 Fifth Avenue NW
New Brighton, Minnesota 55112

*Carriers, including U.S.P.S., airlines, UPS, ground freight, etc., require specific identification of any hazardous materials being shipped. Failure to do so may result in a substantial fine and/or prison term. Check with your shipping company for specific instructions.

