



Pressure Sensitive Regulating Unloader

Models

7670, 7672 7690, 7691

FEATURES

- Provides system pressure setting and protection for single gun (non-weep) and pump installation.
- Compact size with optional ports for easy installation.
- Pressure sensitive feature permits wide range of flows and immediate pressure when gun opens.
- Color coded spring for easy identification and simple change from one model to another.
- Model 7691 has a quick start valve to relieve pump discharge line pressure at start up.

⚠ CAUTIONS AND WARNINGS

All High Pressure Systems require a primary pressure regulating device (i.e. regulator, unloader) and a secondary pressure relief device (i.e. pop-off valve, relief valve). Failure to install such relief devices could result in personal injury or damage to pump or property. CAT PUMPS does not assume any liability or responsibility for the operation of a customer's high pressure system.

Read all CAUTIONS and WARNINGS before commencing service or operation of any high pressure system. The CAUTIONS and WARNINGS are included in each service manual and with each Accessory Data sheet. CAUTIONS and WARNINGS can also be viewed online at www.catpumps.com/cautions-warnings or can be requested directly from CAT PUMPS.

WARRANTY

View the Limited Warranty on-line at www.catpumps.com/warranty.

SPECIFICATIONS

	U.S. Measure	Metric Measure
MODEL 7670		
Flow Range	2.5-8.0 gpm	(9.5-30 lpm)
Pressure Range.....	150-1750 psi	(10-120 bar)
Weight.....	1.66 lbs.	(0.75 kg)
Dimensions.....	7.6 x 3.11 x 2.22"	(179.5 x 79 x 56.5 mm)
MODEL 7672		
Flow Range	2.5-8.0 gpm	(9.5-30 lpm)
Pressure Range.....	850-3200 psi	(60-220 bar)
Weight.....	1.72 lbs.	(0.78 kg)
Dimensions.....	7.6 x 3.11 x 2.22"	(179.5 x 79 x 56.5 mm)
MODEL 7690		
Flow Range	2.5-8.0 gpm	(9.5-30 lpm)
Pressure Range.....	1000-4050 psi	(70-280 bar)
Weight.....	1.75 lbs.	(0.79 kg)
Dimensions.....	7.6 x 3.11 x 2.22"	(179.5 x 79 x 56.5 mm)
MODEL 7691 WITH QUICK START		
Flow Range	2.5-8.0 gpm	(9.5-30 lpm)
Pressure Range.....	1000-4050 psi	(70-280 bar)
Weight.....	1.75 lbs.	(0.79 kg)
Dimensions.....	7.6 x 3.11 x 2.22"	(179.5 x 79 x 56.5 mm)

COMMON SPECIFICATIONS

Maximum Operating Temperatures:

Standard Buna o-rings.....	140°F	(60°C)
Standard Buna o-rings (Intermittent)	195°F	(90°C)
Optional FPM o-rings	240°F	(116°C)
Inlet Ports (2)	3/8" NPTF	(3/8" NPTF)
Discharge Port (1).....	3/8" NPTF	(3/8" NPTF)
By-Pass Port (2).....	3/8" NPTF	(3/8" NPTF)

Unloader is stamped with a European safety pressure. Use only at above specifications to assure proper unloader life and performance.

For Relief Valve version add .100 to unloader model number.
For FPM o-ring version add .0110 to unloader model number.

Read all CAUTIONS and WARNINGS before commencing service or operation of any high-pressure system

SELECTION

These pressure sensitive regulating unloaders are designed for systems with single or multiple pumps, solenoid (gate) valves, nozzles, standard or "weep" guns.

These pressure sensitive regulating unloaders should meet both the desired system flow (combined nozzle flow rate requirement) and the designed system pressure.

Note: Operation below the minimum flow of the unloader causes the unloader to cycle. Operation above the maximum flows of the unloader causes premature unloader wear, cycling and prevents attaining desired system pressure.

INSTALLATION

These unloaders operate properly when mounted in any direction, however, it is preferred to keep the plumbing to a minimum and the adjusting handle easily accessible. The best mounting location is directly on the pump discharge manifold head.

The inlet connections on this unloader are 3/8" NPTF ports and are located on the left side and bottom. Arrows and the word "IN" are cast into the body indicating the direction of flow. A new unloader will have a plug in the bottom port, but this plug can be switched to the left side port if needed. Liquid from the discharge of the manifold goes through these connections.

The discharge connection on this unloader is a 3/8" NPTF port and is located on the front side (hex end). An arrow and the word "OUT" is cast into the body indicating the direction of flow. Plumbing to the spray guns, solenoid (gate) valves or nozzles are connected here.

The by-pass connections on this unloader are 3/8" NPTF ports and are located on the back side and front face. The word "BY PASS" is cast into the body indicating the direction of flow. By-pass liquid is directed out of this port and can be routed to a reservoir (preferred method), or to a drain or to the pump inlet.

OPERATION

These pressure sensitive regulating unloaders hold established system pressure in the discharge line when the trigger gun is closed or solenoid (gate) valve is closed or the nozzle is clogged, thus by-passing all unrequired flow. Squeezing the trigger gun or opening the solenoid (gate) valve will close the by-pass and return to established system pressure.

PRESSURE ADJUSTMENT

1. Setting and adjusting the unloader pressure must be done with the system "on".

2. Start the system with unloader backed off to the lowest pressure setting (counterclockwise direction).

3. Squeeze the trigger and read the pressure on the gauge at the pump.

Note: Do not read the pressure at the gun or nozzle.

4. If more pressure is desired, release the trigger, turn adjusting handle one quarter turn in clockwise direction.

5. Squeeze the trigger and read the pressure.

6. Repeat this process until desired system pressure is attained.

7. Once the desired system pressure is reached, stop turning the adjusting handle.

Note: Pressure is not set at the factory.

Note: A minimum by-pass flow of 5% of the unloader rated flow capacity is required for proper unloader performance. If the entire output is directed through the nozzle (zero by-pass) the "cushioning" feature of the by-pass liquid is eliminated and the unloader can wear or malfunction prematurely.

8. If desired system pressure cannot be reached, review TROUBLESHOOTING chart.

9. When servicing existing systems, follow adjustment procedures as stated above.

Note: Do not adjust unloader pressure setting to compensate for a worn nozzle. Check the nozzle as part of the regular maintenance and replace if worn.

Note: A secondary pressure safety relief device (i.e. pop-off valve, safety valve) should be used along with this pressure sensitive regulating unloader. Final adjustment for the relief valve should relieve at 200 psi above the system operating pressure.

Note: By removing the check valve and spring, these unloaders can function as a secondary relief valve.

TYPICAL UNLOADER INSTALLATION

- 1 Pressure Gauge
- 2 By-Pass Hose (Optional)
- 3 Thermal Valve
- 4 Pop-off Valve (secondary safety relief valve)
- 5 Triplex Plunger Pump
- 6 Pressure Sensitive Regulating Unloader

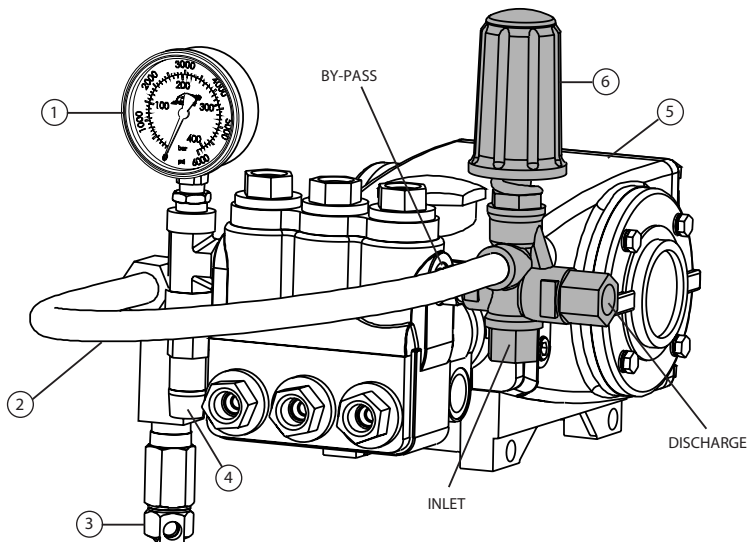

Read all CAUTIONS and WARNINGS before commencing service or operation of any high-pressure system

Disassembly

1. Disconnect by-pass, discharge and inlet plumbing from unloader.
2. Remove unloader from pump.
3. Secure body of unloader in a vise with adjusting handle facing up.
4. Remove discharge fitting and o-ring, spring, check valve and o-ring.
5. Examine check valve and discharge fitting for wear, spring for wear or fatigue and o-rings for cuts or wear and replace as needed with check valve kit.

Note: While the discharge fitting is removed, inspect sealing area where the check valve makes contact within the internal body of the unloader for grooves, pitting and wear. If damage is found, stop the repair and replace with complete new unloader. If not, proceed with disassembly.

6. Remove black nylon cap on top of adjusting handle.
7. Unscrew and remove hex nylock nut.
8. Unscrew and remove adjusting handle, flat washer and spring.
9. Examine all parts for scale build up or wear and replace as needed. Examine spring for fatigue or wear and replace as needed.
10. Remove piston lock pin.
11. Unscrew piston retainer from body of unloader.
12. Grasp threaded end of piston stem and pull from body of unloader. Piston retainer and all associated o-rings should come out upon removal.
13. Unscrew and remove two jam nuts from piston stem.
14. Remove piston retainer, o-rings and back-up-ring. Examine piston retainer for wear. Examine o-rings and back-up-ring for cuts or wear and replace as needed.
15. Examine piston stem for wear. Examine o-ring and back-up-rings for cuts or wear and replace as needed.
16. Remove bottom inlet fitting and o-ring, spring, ball and seat w/o-ring from bottom inlet connection. Examine seat for grooves and o-ring for cuts or wear and replace as needed.

Reassembly

1. At bottom inlet port, lubricate and install o-ring on outside diameter of seat and press seat squarely into position in the body.
2. Install ball and then spring, thread in inlet fitting with o-ring.
3. Lubricate and install back-up-ring and then o-ring into inside diameter of piston retainer. Lubricate and install larger o-ring over threads of piston retainer body. Slide piston retainer with threads facing downwards over piston stem.
4. Apply Loctite®242® to the last few threads of the piston stem. Hand thread two jam nuts to bottom threads of piston stem.
5. Lubricate and install in this order: back-up-ring, o-ring and then back-up-ring onto opposite end of piston stem.
6. Pull piston retainer by hand towards piston stem tip and align slot in piston retainer with hole in piston stem. Install piston lock pin.
7. Grasp threaded end of piston stem and thread in by hand into unloader body, tighten with wrench.
8. Slide spring over piston stem. Install flat washer on top of spring.
9. Thread adjusting handle onto piston stem.
10. Install hex nylock nut onto piston stem.
11. At discharge side of unloader, lubricate and install o-ring onto check valve. Place spring inside check valve. Insert check valve with o-ring and spring into discharge port of unloader body.
12. Lubricate and install o-ring onto threaded end of discharge fitting. Thread in discharge fitting to discharge port of unloader body and tighten with wrench.
13. Remove unloader from vise.
14. Re-install unloader onto pump.
15. Reconnect by-pass, discharge and inlet plumbing to unloader.
16. Proceed to PRESSURE ADJUSTMENT.

Loctite® and 242® are registered trademarks of the Henkel Corporation.

TROUBLESHOOTING

Unloader cycles	<ul style="list-style-type: none"> ● Worn O-ring or check valve ● Fitting leaking downstream ● O-ring in gun worn
Liquid leaking from bottom	<ul style="list-style-type: none"> ● O-ring for seat or inlet fitting cut or worn
Liquid leaking from middle	<ul style="list-style-type: none"> ● O-ring for piston worn or cut
Unloader will not come up to pressure	<ul style="list-style-type: none"> ● Not properly sized for system pressure ● Foreign material in unloader ● Piston o-rings worn ● Nozzle worn or too large. ● Jam nuts not properly set
Extreme pressure spikes	<ul style="list-style-type: none"> ● Adjusting handle turned completely into unloader ● Restricted by-pass or no by-pass ● System flow exceeds unloader rating

PRESSURE READING

Approximate Pressure Reading at Gauge	Gauge Between Pump/Unloader	Gauge Between Unloader/Gun-Nozzle-Valve
System in operation (gun open)	system pressure	system pressure
System in by-pass (all guns, valves closed)	low pressure 0-150 PSI	system pressure +200 PSI

EXPLODED VIEW

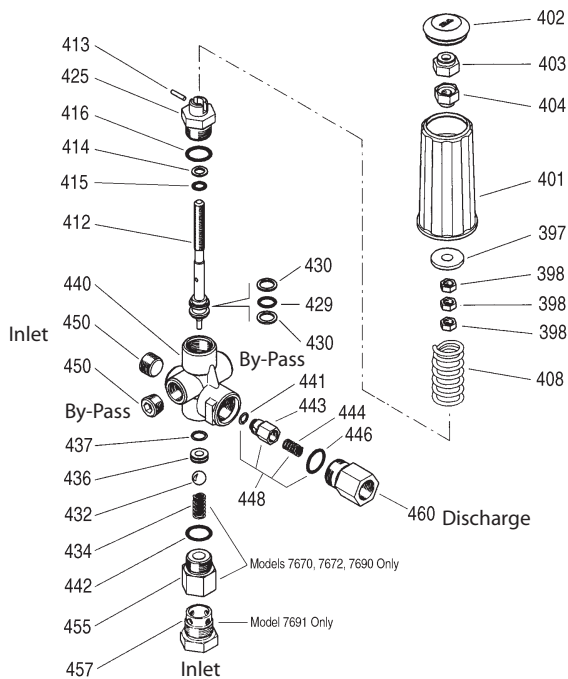

CUTAWAY

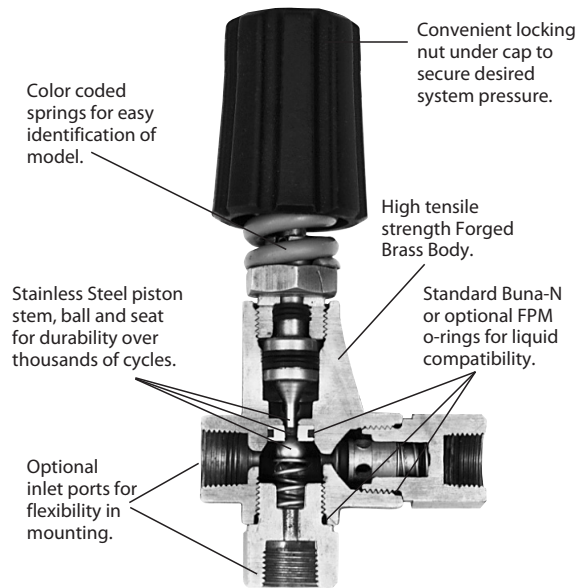

PARTS LIST

ITEM	DESCRIPTION	MODEL NUMBER				QTY
		7670 MATL	7672 MATL	7690 MATL	7691 MATL	
397	Washer, Flat	— STL	— STL	— STL	— STL	1
398	Nut, Jam (M8x1.25)	32116 BB	32116 BB	32116 BB	32116 BB	3
401	Handle, Adjusting	31284 NY	31284 NY	31284 NY	31284 NY	1
402	Cap, Handle	31286 NY	31286 NY	31286 NY	31286 NY	1
403	Nut, Hex, NyLock (M8)	— STZP	— STZP	— STZP	— STZP	1
404	Nut, Adjust (M8)	— BB	— BB	— BB	— BB	1
408	Spring, White (1750 PSI)	32090 STL	—	—	—	1
	Spring, Blue (3450 PSI)	—	32092 STL	32092 STL	32092 STL	1
412	Stem, Piston	33219 S	33219 S	33219 S	33219 S	1
413	Pin, Piston, Lock	32818 S	32818 S	32818 S	32818 S	1
414	Back-up-Ring, Piston Stem	32873 PTFE	32873 PTFE	32873 PTFE	32873 PTFE	1
415	O-Ring, Piston Stem	— NBR/FPM	— NBR/FPM	— NBR/FPM	— NBR/FPM	1
416	O-Ring, Retainer	— NBR/FPM	— NBR/FPM	— NBR/FPM	— NBR/FPM	1
425	Retainer, Piston	33318 BB	33318 BB	33318 BB	33318 BB	1
429	O-Ring, Piston	— NBR/FPM	— NBR/FPM	— NBR/FPM	— NBR/FPM	1
430	Back-up-Ring, Piston	33303 PTFE	33303 PTFE	33303 PTFE	33303 PTFE	2
432	Ball	32289 SSSS	32289 SSSS	31075 SSSS	31075 SSSS	1
434	Spring	— STZP	— STZP	— STZP	—	1
436	Seat, w/O-Ring	— NBR	— NBR	33806 NBR	33806 NBR	1
437	O-Ring, Seat - 85D	— NBR/FPM	— NBR/FPM	— NBR/FPM	— NBR/FPM	1
440	Body	— FBB	— FBB	— FBB	— FBB	1
441	O-Ring, Check Valve	— NBR/FPM	— NBR/FPM	— NBR/FPM	— NBR/FPM	1
442	O-Ring, Inlet Fitting	— NBR/FPM	— NBR/FPM	— NBR/FPM	— NBR/FPM	1
443	Valve, Check	33852 BB	33852 BB	33852 BB	33852 BB	1
444	Spring, Check Valve	33843 S	33843 S	33843 S	33843 S	1
446	O-Ring, Discharge Fitting	— NBR/FPM	— NBR/FPM	— NBR/FPM	— NBR/FPM	1
448	Kit, Check Valve (Incls: 441, 443, 444, 446)	31370 NBR	31370 NBR	31371 BB	31371 BB	1
450	Plug (3/8" NPTM)	46690 BB	46690 BB	46690 BB	46690 BB	2
455	Fitting, Inlet (3/8" NPTF)	32111 BB	32111 BB	31211 BB	—	1
457	Plug, Quick Start	—	—	—	— BB	1
458	Kit, Valve (Incls: 432, 434, 436, 442)	33147 NBR	33147 NBR	31147 NBR	—	1
460	Fitting, Discharge (3/8" NPTF)	33855 BB	33855 BB	33855 BB	33855 BB	1
468	Kit, O-Ring (Incls: 414, 415, 416, 429, 430, 437, 441, 442, 446)	31365 NBR	31365 NBR	31366 NBR	31366 NBR	1
	Kit, O-Ring (Incls: 414, 415, 416, 429, 430, 437, 441, 442, 446)	31375 FPM	31375 FPM	31375 FPM	31375 FPM	1

Bold print part numbers are unique to a particular model. Italics are optional items.

MATERIAL CODES (Not Part of Part Number): BB=Brass FBB=Forged Brass FPM=Fluorocarbon NBR=Medium Nitrile (Buna-N)
 NY=Nylon PTFE=Pure Polytetrafluoroethylene S=304SS SSSS=440SS STL=Steel STZP=Steel/Zinc Plated



CAT PUMPS

1681 - 94TH LANE N.E. MINNEAPOLIS, MN 55449-4324
 PHONE (763) 780-5440 — FAX (763) 780-2958
 e-mail: techsupport@catpumps.com
 www.catpumps.com